



Y-Pattern Valves



ENGINEERING GUIDE

Contact Spears® for any Information not found.

Valves Technical Y-Pattern Valves



Sample Engineering Specification

All thermoplastic valves shall be Y-Pattern configuration constructed from PVC, ASTM D 1784 Cell Classification 12454, or CPVC, ASTM D 1784 Cell Classification 23447. All valves shall have Buttress thread bonnet and standard O-ring type seating disc. All O-rings shall be EPDM or FKM. All valves shall have high impact polypropylene handles. All 1/2" - 2" valves shall be pressure rated at 150 psi and all 3" - 4" valves shall be pressure rated at 90 psi for water at 73°F, as manufactured by Spears® Manufacturing Company.

Quick-View Valve Selection Chart

Valve Size	O-ring Material	PVC Material ^{1,2,3}					Pressure Rating	
		Socket	SR Threaded	Flanged	Socket Union	SR Threaded Union		
1/2"	EPDM	1722-005	1721-005SR	1723-005	172A-005	172B-005SR	150 psi Non-Shock Water @73°F	
	FKM	1732-005	1731-005SR	1733-005	173A-005	173B-005SR		
3/4"	EPDM	1722-007	1721-007SR	1723-007	172A-007	172B-007SR		
	FKM	1732-007	1731-007SR	1733-007	173A-007	173B-007SR		
1"	EPDM	1722-010	1721-010SR	1723-010	172A-010	172B-010SR		
	FKM	1732-010	1731-010SR	1733-010	173A-010	173B-010SR		
1-1/4"	EPDM	1722-012	1721-012SR	1723-012	172A-012	172B-012SR		
	FKM	1732-012	1731-012SR	1733-012	173A-012	173B-012SR		
1-1/2"	EPDM	1722-015	1721-015SR	1723-015	172A-015	172B-015SR		
	FKM	1732-015	1731-015SR	1733-015	173A-015	173B-015SR		
2"	EPDM	1722-020	1721-020SR	1723-020	172A-020	172B-020SR		
	FKM	1732-020	1731-020SR	1733-020	173A-020	173B-020SR		
3"	EPDM	1722-030	1721-030SR	1723-030	172A-030	172B-030SR		90 psi Non-Shock Water @73°F
	FKM	1732-030	1731-030SR	1733-030	173A-030	173B-030SR		
4"	EPDM	1722-040	1721-040SR	1723-040	172A-040	172B-040SR		
	FKM	1732-040	1731-040SR	1733-040	173A-040	173B-040SR		

1: For CPVC Y-Pattern, add the letter "C" to the part number (e.g. 1722-005C)
 2: For PVC Clear Y-Pattern, add the letters "CL" to the part number (e.g. 1722-005CL) or (e.g. 172A-005CL)
 3: For CPVC or Clear Special Reinforced Y-Pattern, (e.g. 1721-005CSR) or (e.g. 1721-005CLSR)

Features - PVC Gray, PVC Clear & CPVC

The Y-Pattern valve is a closing-down, globe type valve design that provides proportional opening to seating disc travel. As such, Y-Pattern valves are ideally suited for flow regulating applications. The Y-pattern configuration reduces pressure loss over that of standard globe valves. Available in IPS Sizes 1/2" - 4" with socket, SR threaded, flanged, socket union or SR threaded union end connectors.

- Chemical & Corrosion Resistant PVC Gray, PVC Clear or CPVC Construction
- Buttress Thread Bonnet
- Fully Serviceable, Replaceable Components
- Standard O-ring Seal Seating Disc & Seals
- EPDM or FKM O-rings
- High Impact Polypropylene Handle
- Assembled with Silicone-Free, Water Soluble Lubricants
- Sizes 1/2" - 2" Pressure Rated to 150 psi @ 73°F, Sizes 3" - 4" Pressure Rated to 90 psi @ 73°F

Replacement Parts - NEXT PAGE

NO.	COMPONENT	QTY.	MATERIAL
1	Body ¹ (SOC/SR/FLG/UNION)	1	PVC/CLEAR/CPVC
2	Stem Assembly	1	PVC/CPVC;EPDM/FKM
3	Seal Carrier O-ring	1	EPDM/FKM
4	Bonnet Nut	1	PVC/CPVC
5	Bonnet	1	PVC/CPVC
6	Handwheel	1	PP
7	Stem Nut	1	PVC
8	Union O-ring	2	EPDM/FKM
9	Union Socket End	2	PVC/CPVC
10	Union SR Thread End	2	PVC/CPVC

1 - SR-Fipt Body Includes: Body (1), Spigot Adapters (2), SS Collars (2)
 - Flange Body Includes: Body (1), Spigot Hubs (2), Flange Rings (2)
 - Union Body Includes: Body (1), Spigot Ends (2), Nuts (2)
 2 - Stem Assembly Includes: Stem (1), Seat Retainer (1), Seat Plate (1), Seal (1), Seal Carrier (1), Retainer Plate (1) (Except 4"), Stem O-ring (1)

Temperature Pressure Rating

System Operating Temperature °F (°C)		100 (38)	110 (43)	120 (49)	130 (54)	140 (60)	150 (66)	160 (71)	170 (77)	180 (82)	190 (88)	200 (93)	210 (99)
Valve Pressure Rating psi (MPa)	1/2" - 2"	PVC	150 (1.03)	135 (.93)	110 (.76)	75 (.52)	50 (.34)	-0-	-0-	-0-	-0-	-0-	-0-
		CPVC	150 (1.03)	140 (.97)	130 (.90)	120 (.83)	110 (.76)	100 (.70)	90 (.62)	80 (.55)	70 (.48)	60 (.41)	50 (.34)
	3" - 4"	PVC	90 (.70)	85 (.62)	75 (.52)	60 (.41)	40 (.30)	-0-	-0-	-0-	-0-	-0-	-0-
		CPVC	90 (.70)	85 (.62)	80 (.55)	75 (.52)	70 (.48)	60 (.41)	50 (.34)	45 (.31)	40 (.30)	35 (.24)	30 (.21)

C_v Values

Size	Values
1/2"	6.7
3/4"	12.6
1"	22.9
1-1/4"	33.8
1-1/2"	50.7
2"	79.2
3"	235
4"	387



Valves Technical Y-Pattern Valves

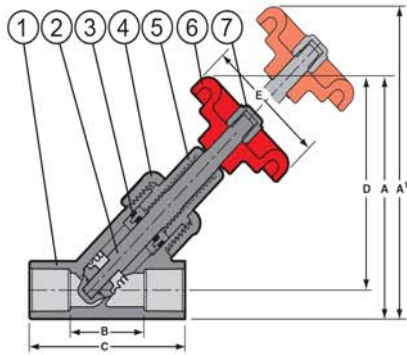

Socket Y-Pattern Dimensions & Weights

Nominal Size	Dimension Reference (inches, ± 1/16)						Approx. Wt. (Lbs.)	
	A ¹	A	B	C	D	E	Socket	
							PVC	CPVC
1/2	6-3/8	4-9/16	1-5/8	3-3/8	4	2-3/8	.31	.33
3/4	7-1/2	5-1/4	2	4	4-9/16	2-3/8	.50	.53
1	6-15/16	5-7/8	2-1/2	4-3/4	5-1/8	2-3/8	.78	.90
1-1/4	10-15/16	7-5/8	3-1/16	5-9/16	6-1/2	3-1/2	1.21	1.28
1-1/2	12	8-5/8	3-9/16	6-5/16	7-1/2	3-1/2	1.66	1.76
2	13-13/16	9-15/16	4-1/2	7-1/2	8-1/2	3-1/2	2.96	3.10
3	20	14-1/2	6-9/16	10-5/16	12-7/16	6-5/8	5.34	5.64
4	25-1/2	18-1/4	8-5/8	13-1/8	15-5/8	7-15/16	9.97	10.45

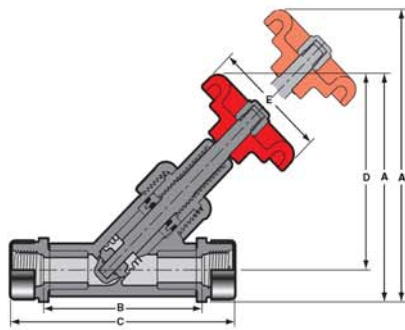

SR Threaded Y-Pattern Dimensions & Weights

Nominal Size	Dimension Reference (inches, ± 1/16)						Approx. Wt. (Lbs.)	
	A ¹	A	B	C	D	E	SR Threaded	
							PVC	CPVC
1/2	6-1/2	4-11/16	3-5/8	5-1/16	4	2-3/8	.31	.33
3/4	7-5/8	5-7/16	4-3/8	5-13/16	4-9/16	2-3/8	.50	.53
1	8-5/8	6-1/8	5-3/16	7	5-1/8	2-3/8	.85	.90
1-1/4	11-1/8	7-3/4	6	7-15/16	6-1/2	3-1/2	1.21	1.28
1-1/2	12-1/4	8-7/8	6-15/16	8-13/16	7-1/2	3-1/2	1.66	1.76
2	14-1/16	10-3/16	8-1/8	10-1/8	8-1/2	3-1/2	2.96	3.10
3	20	14-13/16	11	14-1/4	12-7/16	6-5/8	5.34	5.64
4	25-13/16	18-1/2	14	14-3/4	15-5/8	7-15/16	9.97	10.45

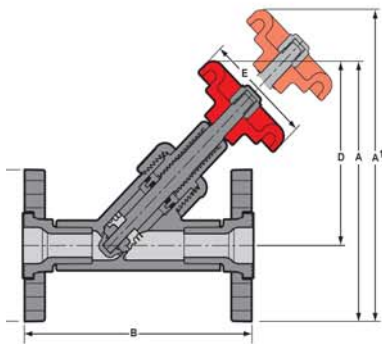

Flanged Y-Pattern Dimensions & Weights

Nominal Size	Dimension Reference (inches, ± 1/16)						Approx. Wt. (Lbs.)	
	A ¹	A	B	C	D	E	Flanged	
							PVC	CPVC
1/2	7-9/16	5-3/4	5-11/16	3-1/2	4	2-3/8	.82	.85
3/4	8-3/4	6-1/2	6-7/16	3-7/8	4-9/16	2-3/8	1.23	1.28
1	9-3/4	7-1/4	7-1/4	4-1/4	5-1/8	2-3/8	1.70	1.81
1-1/4	12-1/4	8-7/8	8-1/8	4-5/8	6-1/2	3-1/2	2.40	2.52
1-1/2	13-3/8	10	9-3/16	5	7-1/2	3-1/2	3.07	3.25
2	15-3/8	11-1/2	10-3/8	6	8-1/2	3-1/2	5.20	5.42
3	21-11/16	16-3/16	12-1/16	7-1/2	12-7/16	6-5/8	9.44	10.07
4	27-7/16	20-3/16	14-9/16	9-1/16	15-5/8	7-15/16	14.87	16.15

Note: 4" flanged Y-Pattern uses split flange ring

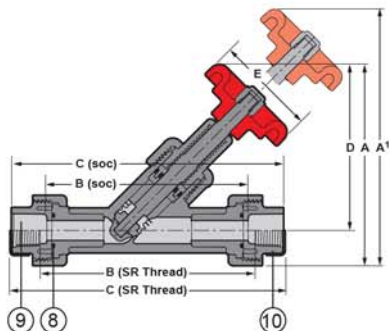

True Union Y-Pattern Dimensions & Weights

Nominal Size	Dimension Reference (inches, ± 1/16)						Approx. Wt. (Lbs.)			
	A ¹	A	B		C		D	E	Union	
			Socket	SR Thread	Socket	SR Thread			PVC	CPVC
1/2	7	5-3/16	5-1/8	5-1/2	6-7/8	7	4-1/4	2-5/8	.59	.62
3/4	8-3/16	6	5-7/8	6-7/16	7-7/8	7-7/8	4-7/8	2-5/8	.97	1.02
1	9-1/8	6-5/8	6-1/2	7-3/8	8-3/4	9	5-3/8	2-5/8	1.33	1.41
1-1/4	11-1/2	8-3/16	7-7/16	6-3/16	9-15/16	10-1/8	6-5/8	3-1/2	1.53	1.63
1-1/2	12-13/16	9-3/8	8-3/16	9	10-15/16	10-15/16	7-9/16	3-1/2	3.06	3.25
2	14-9/16	10-11/16	9-7/16	10-13/16	12-7/16	12-13/16	8-5/8	3-1/2	4.90	5.16
3	21-1/8	15-5/8	13-5/8	15-3/8	17-3/8	18-3/16	12-1/2	6-5/8	14.06	14.37
4	25	19-7/16	17-1/16	19-1/4	21-5/8	22-5/16	7-15/16	7-15/16	17.39	19.23