

Valves Technical
Compression Utility Swing & Spring Check Valves



Features - PVC White & PVC Clear

Spears® Compression Utility Swing Check Valves offer a compact, high performance check valve with EPDM gasketed compression-type ends for fast, convenient connection to virtual and IPS size pipe, plastic or metal. Maintenance-free sealed unit design features long-life EPDM elastomer seats and weighted disc for full flow with minimal restriction and positive shutoff. Produced from PVC White or PVC Clear with White compression end connectors and EPDM seats. Available in IPS Sizes 1/2" through 4".

- Standard Swing Check Assembly Maintains a Positive Seal
- Convenient Compression Ends for Quick Connections
- Engineered for Maximum Flow, Quick Response & Positive Shutoff
- Excellent for Pool & Spa, OEM and General Purpose Applications
- Compact, Space-Saving Design
- Replaceable PVC White or Clear Sealed Unit
- High Grade EPDM Seat
- Suitable for Horizontal or Vertical Up-flow Installations
- Pressure Rated to 150 psi @ 73°F Full Flow (open), 75 psi Back Pressure (closed)
- Maximum Service Temperature 140°F (temperature/pressure de-ratings apply)

Sample Engineering Specification

All thermoplastic check valves shall be Utility Compression Swing Check type constructed from PVC Type I, ASTM D 1784 Cell Classification 12454. All valves shall be maintenance free seal unit construction with EPDM seat and weighted disc. All valves shall have external flow arrow direction designation. All valves shall be certified by NSF International for use in potable water service. All valves shall be pressure rated to 150 psi for water @ 73°F in full flow (open) position and to 75 psi @ 73°F back pressure (closed), as manufactured by Spears® Manufacturing Company.

Quick-View Compression Utility Swing Check Valve Selection Chart

Valve Size	Seat Material	PVC Material ¹	Pressure Rating
		Compression	
1/2	EPDM	S1500-05	150 psi @ 73°F Full Flow (Open)
3/4	EPDM	S1500-07	
1	EPDM	S1500-10	
1-1/4	EPDM	S1500-12	
1-1/2	EPDM	S1500-15	
2	EPDM	S1500-20	75 psi Back Pressure (Closed)
2-1/2	EPDM	S1500-25	
3	EPDM	S1500-30	
4	EPDM	S1500-40	

¹: For PVC Clear, replace dash (-) separator with the letter "C" in the part number (e.g. S1500C05).



Compression Coupling Nut Wrenches

Part Number	Size
CCW-005	1/2
CCW-007	3/4
CCW-010	1
CCW-012	1-1/4
CCW-015	1-1/2
CCW-020*	2
CCW-030**	3

* CCW-020 - Wrench also fits 2-1/2" Coupling Body
 **CCW-030 - Wrench also fits 4" Coupling Body

Compression Coupling Nut Wrench Sets

Part Number	Size
CCW-000	Set
Complete Set of Wrenches, Sizes 1/2" - 3"	



Valves Technical
Compression Utility Swing & Spring Check Valves

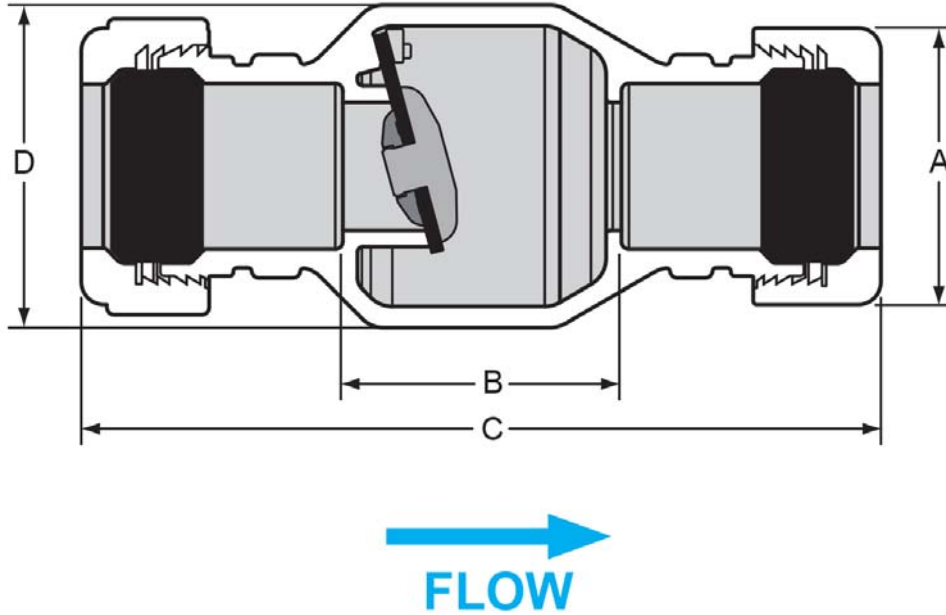

WARNING: The compression joints provide a positive seal but do not restrain pipe from thrust and movement under pressure. Use of compression joint requires blocking of connecting pipe to prevent any movement. Failure to do so can result in system failure or severe personal injury. Use in cold water/fluid applications only.

Dimensions

Nominal Size	Dimension Reference (inches, ± 1/16)			
	A	B	C	D
1/2	1-13/16	1-15/16	6-1/8	2-1/8
3/4	2-1/8	1-15/16	6-1/8	2-1/8
1	2-1/2	2-1/2	6-3/4	2-5/8
1-1/4	2-15/16	2-15/16	8-1/2	3-3/8
1-1/2	3-5/16	2-15/16	8-3/4	3-3/8
2	3-29/32	3-19/32	9-9/16	4-1/4
2-1/2	4-15/16	4-3/8	11-5/16	5-1/8
3	5-1/2	4-11/16	12-13/16	5-3/4
4	6-3/4	5-15/16	16-1/2	7-3/16

General Installation Information: Swing check valves are designed for horizontal installations, but may be installed in up-flow only vertical position. Check valves **MUST** be installed with the valves **FLOW** arrow pointing in the direction of the flow. Do not install valve upside down. Flow velocity should not exceed 5 ft./sec. Minimum opening pressure less than 0.5 psi.

Temperature Pressure Rating

System Operating Temperature °F (°C)			100 (38)	110 (43)	120 (49)	130 (54)	140 (60)	150 (66)	160 (71)	170 (77)	180 (82)	190 (88)	200 (93)	210 (99)
Valve Pressure Rating psi (MPa)	1/2" - 4"	PVC	150 (1.03)	135 (.93)	110 (.76)	75 (.52)	50 (.34)	-0- (-0-)	-0- (-0-)	-0- (-0-)	-0- (-0-)	-0- (-0-)	-0- (-0-)	-0- (-0-)