



Gate Valves



ENGINEERING GUIDE

Contact Spears® for any Information not found.

Valves Technical Plug Gate Valves



Sample Engineering Specification

All thermoplastic valves shall be Plug Gate style constructed from PVC Type I, ASTM D 1784 Cell Classification 12454 or CPVC Type IV, ASTM D 1784 Cell Classification 23447, with Polypropylene bonnets and high impact Polypropylene hand wheel. All valves shall have non-rising stem and Plug-style Polyethylene gate with Strain-Equalizing thread. All valve components shall be replaceable. All 1/2" - 2" valves shall be pressure rated to 235 psi and all flanged valves 1/2" - 8" to 150 psi for water @ 73°F, as manufactured by Spears® Manufacturing Company.

Features — PVC, CPVC

Spears® Plug Gate Valve utilizes a cylindrical "plug-style" gate for more uniform sealing and positive shutoff. Low-profile, compact design and non-rising stem saves space for the most demanding applications. Spears® Strain-Equalizing stem/wedge design combined with improved Polypropylene bonnet makes this one of the most reliable thermoplastic gate valves available. Valves are produced from PVC or CPVC bodies in IPS sizes of 1/2" - 2" with Socket & SR Threaded or 1/2" - 8" Flanged end connections.

- Chemical & Corrosion Resistant PVC or CPVC Construction with Polypropylene Bonnet
- Polyethylene Plug-Style Gate Provides Cylindrical Internal Seal
- Non-Rising Stem with Patented Strain-Equalizing Threads
- 6" and 8" Valves Features Built-in Position Indicator
- High-Impact Polypropylene Hand Wheel
- Fully Serviceable In-line with Repair Kits or Full Internal Replacement Cartridges
- Buna-N, EPDM or FKM O-ring Seals
- Sizes 1/2" — 2" Pressure Rated to 235 psi @ 73°F Flanged through 8" to 150 psi @ 73°F
- Suitable for Vacuum Service
- Assembled with Silicone-Free, Water Soluble Lubricants
- Optional 2" Square/T-Style Operator Nut available.

Quick-View Valve Selection Chart

Valve Size	O-ring Material	PVC Part Numbers ¹			Pressure Rating	
		Socket	SR Threaded	Flanged		
1/2	Buna-N	5212-005	5211-005SR	5213-005	235 psi Non-Shock Water @ 73°F	
	EPDM	5222-005	5221-005SR	5223-005		
	FKM	5232-005	5231-005SR	5233-005		
3/4	Buna-N	5212-007	5211-007SR	5213-007		
	EPDM	5222-007	5221-007SR	5223-007		
	FKM	5232-007	5231-007SR	5233-007		
1	Buna-N	5212-010	5211-010SR	5213-010		
	EPDM	5222-010	5221-010SR	5223-010		
	FKM	5232-010	5231-010SR	5233-010		
1-1/4	Buna-N	5212-012	5211-012SR	5213-012		(Flanged 150 psi Non-Shock Water @ 73°F)
	EPDM	5222-012	5221-012SR	5223-012		
	FKM	5232-012	5231-012SR	5233-012		
1-1/2	Buna-N	5212-015	5211-015SR	5213-015		
	EPDM	5222-015	5221-015SR	5223-015		
	FKM	5232-015	5231-015SR	5233-015		
2	Buna-N	5212-020	5211-020SR	5213-020		
	EPDM	5222-020	5221-020SR	5223-020		
	FKM	5232-020	5231-020SR	5233-020		
6	EPDM	---	---	5223-060		
	FKM	---	---	5233-060		
8	EPDM	---	---	5223-080		
	FKM	---	---	5233-080		

1: For CPVC valves, add the letter "C" to the part number (e.g. 5222-005C, 5211-005CSR)

Plug Gate Valve O-ring Repair Kit

All kits include Stem O-ring (2), Bonnet O-ring (1).

Valve Size	Part Number		
	Buna-N O-ring	EPDM O-ring	FKM O-ring
1/2, 3/4 & 1	PGT-BRK-010	PGT-ERK-010	PGT-VRK-010
1-1/4, 1-1/2 & 2	PGT-BRK-020	PGT-ERK-020	PGT-VRK-020
6	---	PGT-ERK-060	PGT-VRK-060
8	---	PGT-ERK-080	PGT-VRK-080

Plug Gate Valve Internal Replacement Cartridge

Internal Replacement Cartridge includes complete, fully assembled Handle Nut, Stem O-ring, Bonnet O-ring, and Gate for direct insertion into existing valve body.

Valve Size	Part Number					
	Buna-N O-rings	CPVC w/ Buna-N O-rings	EPDM O-rings	CPVC w/ EPDM O-rings	FKM O-rings	CPVC w/ FKM O-rings
1/2, 3/4 & 1	5210-010	5210-010C	5220-010	5220-010C	5230-010	5230-010C
1-1/4, 1-1/2 & 2	5210-020	5210-020C	5220-020	5220-020C	5230-020	5230-020C
6	---	---	5220-060	5220-060C	5230-060	5230-060C
8	---	---	5220-080	5220-080C	5230-080	5230-080C



Valves Technical Plug Gate Valves

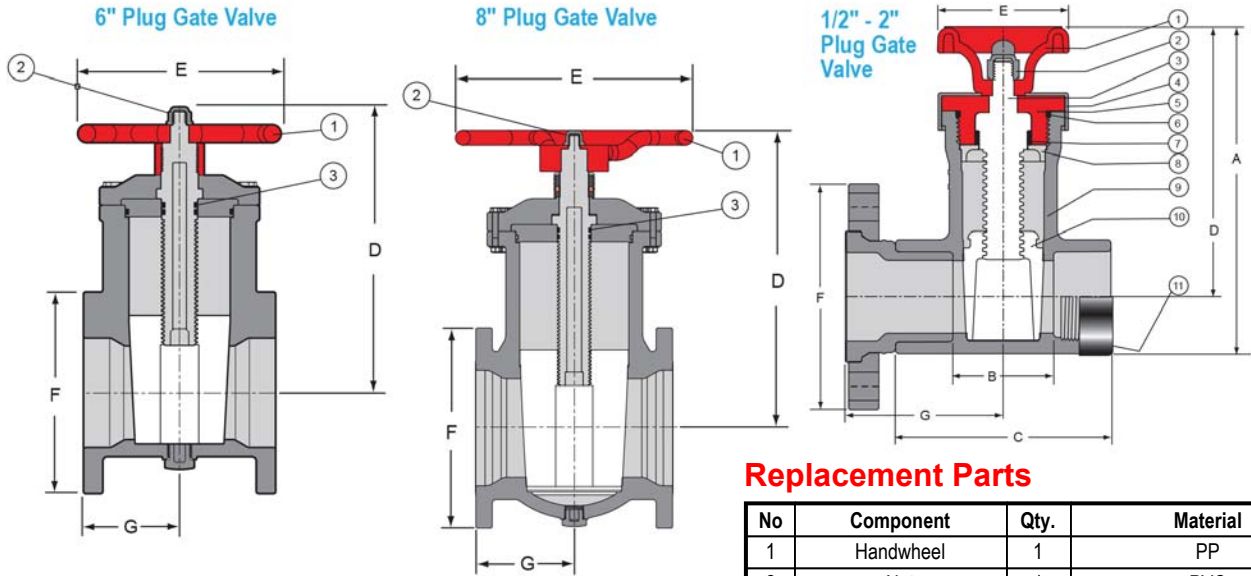

Replacement Parts

No	Component	Qty.	Material
1	Handwheel	1	PP
2	Nut	1	PVC
3	Stem O-Ring	2	EPDM, FKM

Replacement Parts

No	Component	Qty.	Material
1	Handwheel	1	PP
2	Nut	1	PVC
3	Stem	1	PP
4	Bonnet Retainer	1	PVC
5	Bonnet	1	PP
6	Bonnet O-ring	1	Buna-N, EPDM, FKM
7	Stem O-ring	2	Buna-N, EPDM, FKM
8	Stem Support	1	PVC/CPVC
9	Body	1	PVC/CPVC
10	Gate	1	PE
11	SS Collar	2	SS 316

Dimensions & Weights

Nominal Size	Dimension Reference (inches)								Approx. Wt. (Lbs.)			
	A	B		C	D	E	F	G	PVC		CPVC	
		Socket	SR Thread						Soc/Thd	Flanged	Soc/Thd	Flanged
1/2	5	1-1/4	1-11/16	3-1/16	4-1/8	2-5/8	3-1/2	2-11/32	.38	.77	.39	.80
3/4	5	1-1/4	1-15/16	3-5/16	4-1/8	2-5/8	3-7/8	2-1/2	.40	.95	.41	.99
1	5	1-1/4	1-3/4	3-1/2	4-1/8	2-5/8	4-1/4	2-21/32	.43	1.21	.44	1.27
1-1/4	8-5/8	2-21/32	3-7/16	5-1/4	7-1/8	3-7/16	4-5/8	3-5/8	1.84	2.83	1.85	2.89
1-1/2	8-5/8	2-21/32	3-5/8	5-15/32	7-1/8	3-7/16	5	3-15/16	1.94	3.15	1.98	3.27
2	8-5/8	2-21/32	3-27/32	5-23/32	7-1/8	3-7/16	5-15/16	4-5/32	2.11	3.99	2.17	4.18
6	---	---	---	---	15-5/8	10-7/8	11	5-1/4	---	35.53	---	43.56
8	---	---	---	---	20-1/16	16	13-1/2	6-5/8	---	54.59	---	74.55

Temperature Pressure Rating

System Operating Temperature °F (°C)		100 (38)	110 (43)	120 (49)	130 (54)	140 (60)	150 (66)	160 (71)	170 (77)	180 (82)	190 (88)	200 (93)	210 (99)	
Valve Pressure Rating psi (MPa)	1/2" - 2"	PVC	235 (1.62)	140 (.97)	130 (.90)	90 (.62)	50 (.34)	-0- (-0-)	-0- (-0-)	-0- (-0-)	-0- (-0-)	-0- (-0-)	-0- (-0-)	
		CPVC	235 (1.62)	219 (1.51)	170 (1.17)	145 (1.00)	130 (.90)	110 (.76)	95 (.66)	80 (.55)	70 (.48)	60 (.41)	50 (.34)	-0- (-0-)
	6" - 8"	PVC	150 (1.03)	130 (.90)	110 (.76)	60 (.41)	50 (.34)	-0- (-0-)	-0- (-0-)	-0- (-0-)	-0- (-0-)	-0- (-0-)	-0- (-0-)	-0- (-0-)
		CPVC	150 (1.03)	140 (.97)	130 (.90)	120 (.83)	110 (.76)	100 (.69)	90 (.62)	80 (.55)	70 (.48)	60 (.41)	50 (.34)	-0- (-0-)

Features — PVC, CPVC

This solid, proven design is well suited for a variety of chemical, industrial and irrigation applications. Spears® Gate Valves are feature-packed with a variety of end connector options. Individual special features are found in each size range 1/2" through 2", 2-1/2" & 3", and in the full featured Heavy Industrial 4" valve. See Spears® Plug Gate Valves for 6" size.

- Heavy Bodied PVC & CPVC Construction
- Tapered Wedge with Specially Designed Sealing Surface
- Non-Rising Stem Design
- Patented Strain-Equalizing Stem/Wedge Thread
- O-ring Stem Seals Instead of Packing - No Retightening Required
- Buna-N, EPDM, or FKM O-ring Seals
- Positive Grip, High Impact Polypropylene Handwheel Operator
- Fully Serviceable, Replaceable Components - Accessible Without Valve Removal
- EPDM Gate Valves NSF® Certified for Potable Water use
- Suitable for Vacuum Service
- Assembled with Silicone-Free, Water Soluble Lubricants
- Metric Socket and BSP Thread Available, 1/2" - 2"



1/2" - 2" PVC & CPVC Heavy Duty Gate Valves

- Available with socket, threaded or flanged end connectors.
- Pressure rated to 200 psi @ 73°F. Flanged Valve Pressure Rated to 150 psi @ 73°F



2-1/2" & 3" PVC & CPVC Heavy Duty Gate Valves

- Available with socket, SR Threaded (Special Reinforced) threaded or flanged end connectors.
- Pressure rated to 150 psi @ 73°F.
- Optional 2" Square/T-Style Operator Nut available.

Note: 2-1/2" size is a bushed down 3" valve.



4" PVC & CPVC Heavy Industrial Gate Valves

- Available with socket, SR Threaded (Special Reinforced) threaded or flanged end connectors.
- Pressure rated to 235 psi @ 73°F. Flanged Valve Pressure Rated to 150 psi @ 73°F
- SS 316 Exterior Bonnet & Hardware
- Built-in Quick-View Position Indicator
- Optional 2" Square/T-Style Operator Nut available.

Sample Engineering Specification

All thermoplastic Gate Valves shall be constructed from PVC Type I Cell Classification 12454 or CPVC Type IV Cell Classification 23447. All O-rings shall be Buna-N, EPDM or FKM. All EPDM valves shall be NSF® certified for potable water use. All valves shall have non-rising stem and Polypropylene handwheel. All valve gate wedges shall have Strain-Equalizing threads. PVC valves shall have Polypropylene wedge and CPVC valves shall have CPVC wedge. All valve components shall be replaceable. All 1/2" through 2" valves shall be pressure rated at 200 psi, all 2-1/2" through 3" and all flanged valves shall be pressure rated at 150 psi, and all 4" valves shall be pressure rated at 235 psi for water at 73°F, as manufactured by Spears® Manufacturing Company.



Valves Technical Gate Valves

Quick-View Valve Selection Chart

Valve Size	O-ring Material	PVC Part Numbers ¹			Pressure Rating	
		Socket	Threaded	Flanged		
1/2	Buna-N	2012-005	2011-005	2013-005	200 psi Non-Shock Water @ 73°F	
	EPDM	2022-005	2021-005	2023-005		
	FKM	2032-007	2031-005	2033-005		
3/4	Buna-N	2012-007	2011-007	2013-007		
	EPDM	2022-007	2021-007	2023-007		
	FKM	2032-007	2031-007	2033-007		
1	Buna-N	2012-010	2011-010	2013-010		
	EPDM	2022-010	2021-010	2023-010		
	FKM	2032-010	2031-010	2033-010		
1-1/4	Buna-N	2012-012	2011-012	2013-012		(Flanged 150 psi Non-Shock Water @ 73°F)
	EPDM	2022-012	2021-012	2023-012		
	FKM	2032-012	2031-012	2033-012		
1-1/2	Buna-N	2012-015	2011-015	2013-015		
	EPDM	2022-015	2021-015	2023-015		
	FKM	2032-015	2031-015	2033-015		
2	Buna-N	2012-020	2011-020	2013-020		
	EPDM	2022-020	2021-020	2023-020		
	FKM	2032-020	2031-020	2033-020		
2-1/2	Buna-N	2012-025 ³	2011-025 ³	2013-025 ³	150 psi Non-Shock Water @ 73°F	
	EPDM	2022-025 ³	2021-025 ³	2023-025 ³		
	FKM	2032-025 ³	2031-025 ³	2033-025 ³		
3	Buna-N	2012-030	2011-030SR	2013-030		
	EPDM	2022-030	2021-030SR	2023-030		
	FKM	2032-030	2031-030SR	2033-030		
4	Buna-N	2012-040	2011-040SR	2013-040		235 ² psi Non-Shock Water @ 73°F
	EPDM	2022-040	2021-040SR	2023-040		
	FKM	2032-040	2031-040SR	2033-040		

C_v Values

Nominal Size	C _v ¹ Gallons/Minute	
	Socket/Threaded	Flanged
1/2	19	15
3/4	37	29
1	44	39
1-1/4	128	105
1-1/2	144	127
2	333	279
2-1/2	See Note 2	
3	335	323
4	583	566

Flanged valves calculated for additional laying length of flanged valve.

1: Gallons per minute at 1 psi pressure drop.

2: Size 2-1/2" is a reducer bushed down 3" valve, C_v not available.

1: For CPVC valves, add the letter "C" to the part numbers (e.g., 2031-005C).

2: Flanged end connectors have a Maximum Internal Pressure Rating of 150 psi @ 73°F.

3: Outlet sized with bushing.

Temperature Pressure Rating

System Operating Temperature °F (°C)		100 (38)	110 (43)	120 (49)	130 (54)	140 (60)	150 (66)	160 (71)	170 (77)	180 (82)	190 (88)	200 (93)	210 (99)	
Valve Pressure Rating psi (MPa)	1/2"-2"	PVC	200 (1.38)	135 (.93)	120 (.83)	75 (.52)	50 (.34)	-0 (-0)	-0 (-0)	-0 (-0)	-0 (-0)	-0 (-0)	-0 (-0)	
		CPVC	200 (1.38)	155 (1.07)	140 (.97)	125 (.86)	110 (.76)	100 (.69)	90 (.62)	80 (.55)	70 (.48)	60 (.41)	50 (.34)	-0 (-0)
	2-1/2"-3"	PVC	150 (1.03)	130 (.90)	110 (.76)	60 (.41)	50 (.34)	-0 (-0)	-0 (-0)	-0 (-0)	-0 (-0)	-0 (-0)	-0 (-0)	-0 (-0)
		CPVC	150 (1.03)	140 (.97)	130 (.90)	120 (.83)	110 (.76)	100 (.69)	90 (.62)	80 (.55)	70 (.48)	60 (.41)	50 (.34)	-0 (-0)
	4"	PVC	235 (1.62)	140 (.97)	130 (.90)	90 (.62)	50 (.34)	-0 (-0)	-0 (-0)	-0 (-0)	-0 (-0)	-0 (-0)	-0 (-0)	-0 (-0)
		CPVC	235 (1.62)	219 (1.51)	170 (1.17)	145 (1.00)	130 (.90)	110 (.76)	95 (.66)	80 (.55)	70 (.48)	60 (.41)	50 (.34)	-0 (-0)

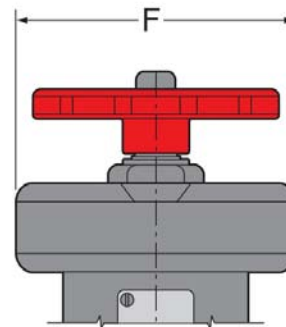
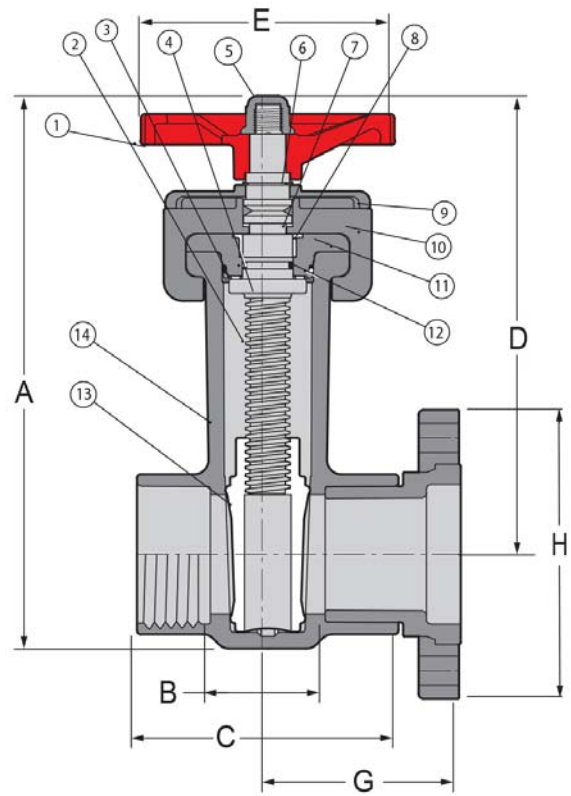
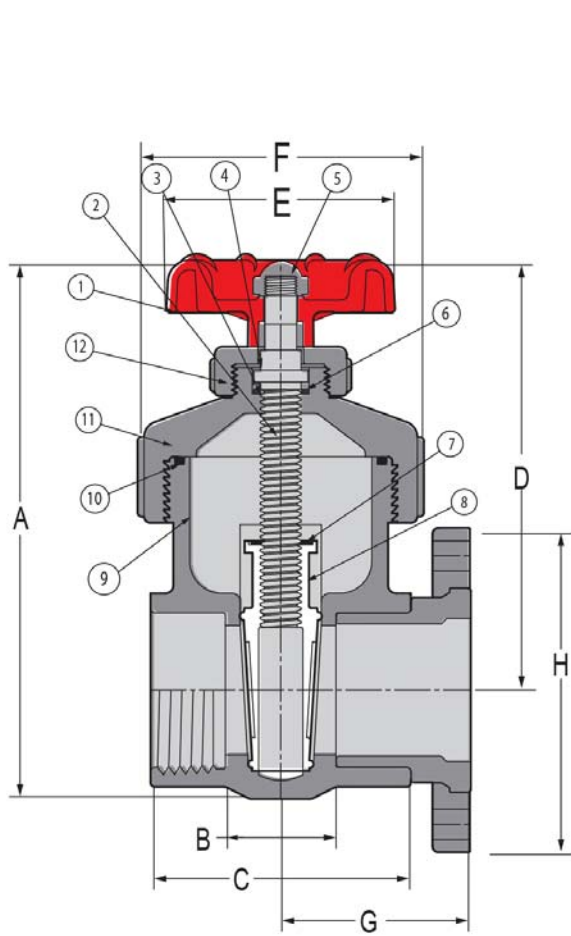

1/2" - 2" Replacement Parts

No.	Component	Qty.	Material
1	Handle	1	PP
2	Stem	1	PVC/CPVC
3	Stem O-ring	1	Buna-N/EPDM/FKM
4	Stem Bushing	1	PP
5	Stem Nut	1	PVC/CPVC
6	Stem Washer	1	PP
7	Wedge Washer/O-ring	1	Buna-N/EPDM/FKM
8	Wedge	1	PP/CPVC
9	Body (Socket/Threaded)	1	PVC/CPVC
10	Bonnet O-ring	1	Buna-N/EPDM/FKM
11	Bonnet	1	PVC/CPVC
12	Bonnet Nut	1	PVC/CPVC

2-1/2" & 3" Replacement Parts

No.	Component	Qty.	Material
1	Handle	1	PP
2	Stem	1	PVC/CPVC
3	Stem Bearing	1	PP
4	Stem O-ring	1	Buna-N/EPDM/FKM
5	Stem Nut	1	PVC
6	Stem Retaining Ring	1	SS 316
7	Split Washer	1	PP
8	Stem Bushing	1	PP
9	Bonnet Retainer	1	PVC/CPVC
10	Bonnet Half	2	PVC/CPVC
11	Seal Carrier	1	PVC/CPVC
12	Carrier O-ring	1	Buna-N/EPDM/FKM
13	Wedge	1	PP/CPVC
14	Body	1	PVC/CPVC



Valves Technical Gate Valves

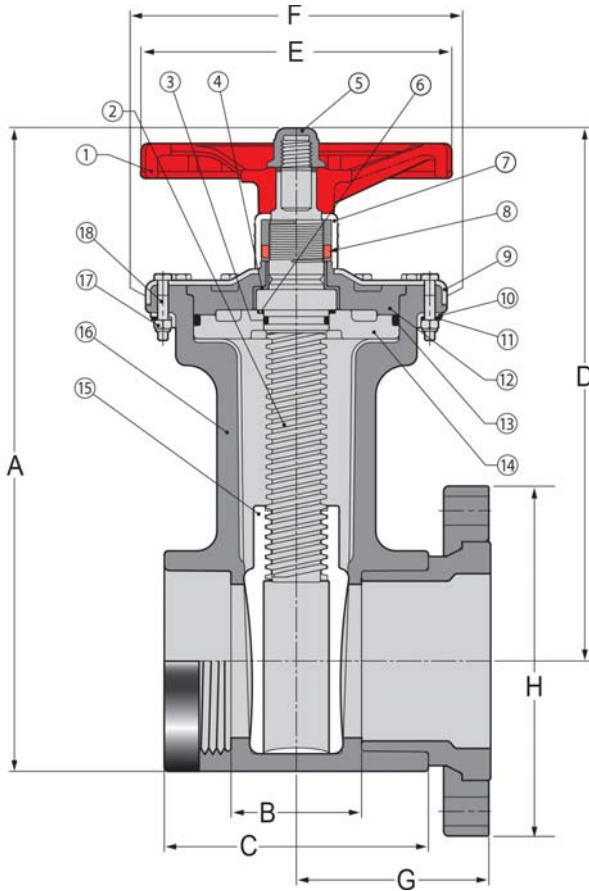

4" Replacement Parts

No.	Component	Qty.	Material
1	Handle	1	PP
2	Stem	1	PVC/CPVC
3	Stem O-ring	1	Buna-N/EPDM/FKM
4	Stem Bushing	1	PTFE/HDPE
5	Stem Nut	1	PVC/CPVC
6	Stem Washer	1	PP
7	Indicator Cover	1	PVC Clear
8	Indicator Nut	1	PP Yellow
9	Bonnet Retainer	1	SS 316
10	Retainer Bracket	2	SS 316
11	Bracket Lock	1	SS 316
12	Bonnet	1	PVC/CPVC
13	Seal Carrier O-ring	1	Buna-N/EPDM/FKM
14	Seal Carrier	1	PVC/CPVC
15	Wedge	1	PP/CPVC
16	Body	1	PVC/CPVC
17	Locknut	12	SS 316
18	Hex Bolt	12	SS 316

Dimensions & Weights

Nominal Size	Dimension Reference (inches, ± 1/16)								Approx. Wt. (Lbs.)			
	A	B ¹	C	D	E	F	G	H	PVC		CPVC	
									Soc/Thd	Flanged	Soc/Thd	Flanged
1/2	5	1-5/16	2-13/16	4-1/8	2-5/8	2-11/16	2-3/8	3-1/2	.51	.92	.56	.98
3/4	5-1/32	1-1/4	2-13/16	4	2-5/8	2-11/16	2-1/2	3-7/8	.52	1.09	.57	1.16
1	5-13/32	1-1/4	3-1/4	4-5/16	2-5/8	2-15/16	2-11/16	4-1/4	.67	1.46	.73	1.54
1-1/4	8-1/16	1-9/16	3-9/16	6-9/16	3-7/16	3-15/16	3	4-5/8	1.61	2.58	1.73	2.74
1-1/2	8-1/16	1-9/16	3-3/4	6-7/8	3-7/16	3-15/16	3-3/8	5	1.63	2.81	1.75	3.03
2	8-9/16	1-11/16	3-15/16	6-7/8	3-7/16	4-7/16	3-5/8	6	1.95	3.81	2.15	4.09
2-1/2	14-5/16	3-3/8	7-3/8	11-7/8	6-11/16	7-1/4	5-1/8	7	9.48	11.91	9.60	12.89
3	14-5/16	2-15/16	6-11/16	11-7/8	6-11/16	7-1/4	4-15/16	7-1/2	9.03	12.21	9.43	13.40
4	16	3-3/8	7-15/16	13-1/4	8	7-9/16	4-7/8	9	13.67	18.39	14.66	19.75

1: Valve Lay Length



2" Square / T-Style Operator Nuts

- Fits Spears® Gate Valves.
- Combination design for use with either standard 2" square drive or conventional "T" drive operators.

Size	Part Number
1/2, 3/4, 1	GTN-005
1-1/4, 1-1/2, 2	GTN-012
2-1/2 & 3	GTN-030
4	GTN-040