

Valves Technical Needle Valves



Features — PVC, CPVC & PP

Needle Valves provide proportional opening to needle travel for more accurate metering applications and other fine adjustment flow control applications. Special design PTFE seal eliminates elastomer type seals or O-rings that can contribute to chemical compatibility problems. PVC, CPVC and Polypropylene valves are available with 1/4", 3/8" and 1/2" NPT female threaded ends in either standard Globe Pattern or special Angle Pattern configuration that eliminates need for additional elbow in various system setups.

- Chemical & Corrosion Resistant PVC, CPVC or PP Construction
- Precision Metering Chamber
- Globe & Angle Body Configurations
- Removable Bonnet For Easy Disassembly & Cleaning
- Solid PTFE Stem Seal - No Elastomer Seal or Lubricants Used
- Built-in Panel or Bracket Mounting Nut
- Easy-Grip Polypropylene Handle
- PVC & CPVC Pressure Rated to 235 psi @ 73°F
Polypropylene Pressure Rated to 150 psi @ 73°F

Sample Engineering Specification

All thermoplastic Needle Valves shall be constructed from PVC, ASTM D 1784 Cell Classification 12454, CPVC, ASTM D 1784 Cell Classification 23447, or Polypropylene, ASTM D 4101. All valves shall be globe pattern or angle pattern body configuration with 1/4", 3/8" or 1/2" female NPT end connections. All valves shall have removable bonnet cap with replaceable PTFE seal. No elastomer seals shall be used. All valves shall have built-in panel mounting nut and high impact polypropylene handles. All PVC and CPVC valves shall be pressure rated to 235 psi and all Polypropylene valves to 150 psi for water @ 73°F, as manufactured by Spears® Manufacturing Company.

C_v Values

Size	Globe Pattern	Angle Pattern
1/4" - 3/8"	.310	.426
1/2"	.62	.78

Gallons per minute at 1 psi pressure drop.

Quick-View Needle Valve Selection Chart

Valve Size	PVC Part Numbers ^{1,2}						Pressure Rating
	Globe Pattern			Angle Pattern			
	Socket	SR Threaded	Threaded	Socket	SR Threaded	Threaded	
1/4"	5592-002	N/A	5591-002	5692-002	N/A	5691-002	PVC & CPVC 235 psi, PP 150 psi Non-Shock Water @ 73°F
3/8"	5592-003	5591-003SR	5591-003	5692-003	N/A	5691-003	
1/2"	5592-005	5591-005SR	5591-005	5692-005	5691-005SR	5691-005	

1: For CPVC Valve, add the letter "C" to the part number (e.g. 5591-002C).

2: For threaded Polypropylene Valve, add the letter "P" to the part number (e.g. 5591-002P, 5591-005PSR).

Temperature Pressure Rating

System Operating Temperature °F (°C)		100 (38)	110 (43)	120 (49)	130 (54)	140 (60)	150 (66)	160 (71)	170 (77)	180 (82)	190 (88)	200 (93)	210 (99)	
Valve Pressure Rating psi (MPa)	1/4"-1/2"	PVC	235 (1.62)	211 (1.45)	150 (1.03)	75 (.52)	50 (.34)	-0- (-0-)	-0- (-0-)	-0- (-0-)	-0- (-0-)	-0- (-0-)	-0- (-0-)	
		CPVC	235 (1.62)	219 (1.51)	170 (1.17)	145 (1.00)	130 (.90)	110 (.76)	90 (.62)	80 (.55)	70 (.48)	60 (.41)	50 (.34)	-0- (-0-)
		PP	150	105	90	80	65	50	45	30	20	-0-	-0-	-0-



Valves Technical Needle Valves

Panel Mounting Instructions

Spears® Needle Valves may be easily mounted to panel or bracket ranging from 3/16" to 1/2" in thickness using the accompanying template. Prepare mounting hole to panel opening dimensions. Slots may be cut in various positions to allow more versatile orientation. Open valve partially. Remove Bonnet Cap with needle assembly (do not fully disassemble) and Panel Nut from valve body. Insert valve body through mounting hole and seat lugs. Reinstall Panel Nut and tighten snug. Carefully reinstall Bonnet Cap and needle assembly, tighten snug. **Caution:** Failure to partially open the valve or back the needle off prior to re-assembly may damage needle when tightening Bonnet Cap.

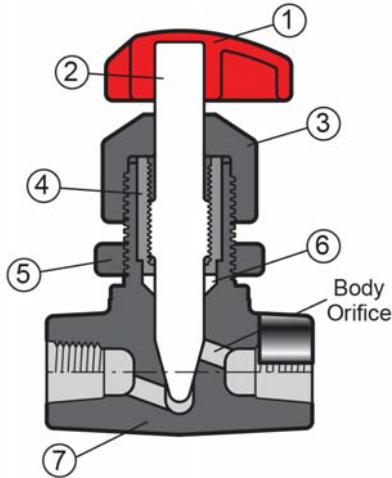

Replacement Parts

No.	Component	Qty.	Material
1	Handle	1	PP
2	Needle Stem	1	PVC/CPVC/PP
3	Bonnet Cap	1	PVC/CPVC/PP
4	Stem Nut	1	GFPP
5	Panel Nut	1	PVC/CPVC/PP
6	Seal	1	PTFE
7	Body	1	PVC/CPVC/PP

Body Orifice Dimensions

Valve Size	Body Orifice Ø
1/4	3/16"
3/8	3/16"
1/2	1/4"

Panel Opening

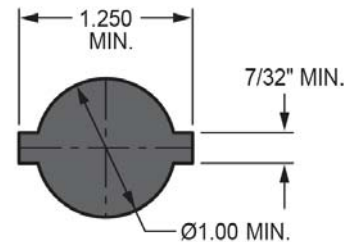

Globe Pattern

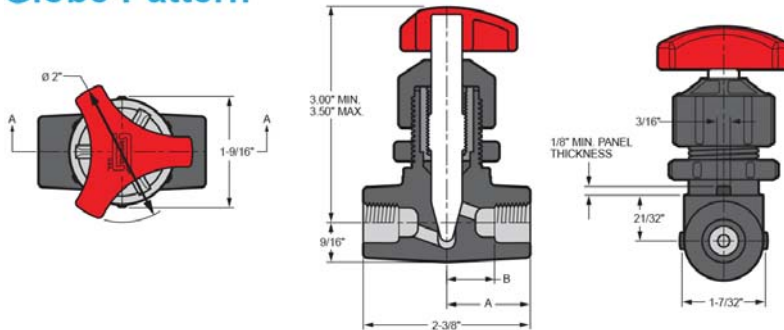

Dimensions

Valve Size	End Connection	A	B
1/4	Threaded	1-3/16	21/32
	Socket		9/16
3/8	Threaded		9/16
	Socket		7/16
1/2	Threaded	1-3/8	21/32
	Socket		1/2

Threaded Valve Dimensions apply to both Standard and SR Threads.

Angle Pattern

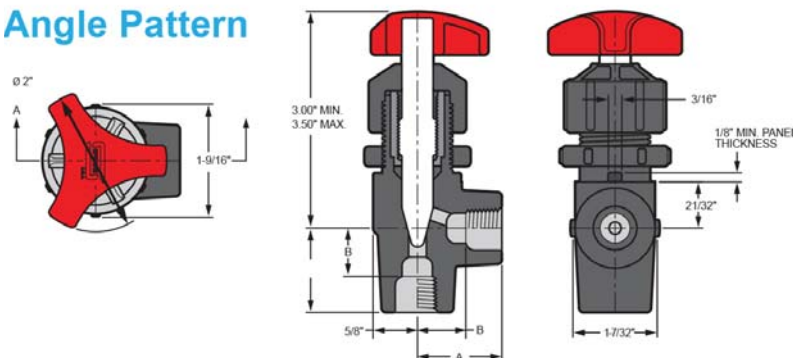

Needle Valve Adapter Kit

Valve Size	O-ring Material	Part Number	
		PVC	CPVC
1/4	EPDM	LVKE-002	LVKE-002C
	FKM	LVKV-002	LVKV-002C

Kit Includes:

- 2 — O-rings
- 1 — End Connector Wrench
- 2 — 1/4" MPT x Mipt Adapters
- 2 — 1/4" MPT x 3/8" I.D. Tubing Barb Adapters