



Features — PVC, CPVC

This versatile quarter-turn shutoff valve is ideally suited for a variety of laboratory, system monitoring and OEM applications. Available in IPS sizes 1/4" - 3/8" with socket or threaded end connectors, plus 1/4" threaded Valve & Adapter Kit to provide multiple connection options.

- Chemical & Corrosion Resistant PVC or CPVC Construction
- Maintenance-Free Sealed Unit
- Individual Valve or Multi-functional Valve & Adapter Kit
- Schedule 80 Full-Port Design
- High Impact Polypropylene Handle
- EPDM or FKM O-rings
- PTFE Floating Seat Design
- Sizes 1/4" - 3/8" Pressure Rated to 150 psi @ 73°F
- EPDM Valves NSF® Certified for Potable Water use
- Assembled with Silicone-Free, Water Soluble Lubricant

Sample Engineering Specification

All thermoplastic valves shall be sealed unit Lab type constructed from PVC Type I, ASTM D 1784 Cell Classification 12454 or CPVC Type IV, ASTM D 1784 Cell Classification 23447. All O-rings shall be EPDM or FKM. All valves shall have double stop Polypropylene handle. All 1/4" valves shall have optional field installable male thread and tubing end connector adapters. All EPDM valves shall be certified by NSF International for use in potable water service. All EPDM valves shall be pressure rated at 150 psi for water at 73°F, as manufactured by Spears® Manufacturing Company.

Quick-View Valve Selection Chart

Valve Size	O-ring Material	PVC Part Number ^{1,2}			Pressure Rating
		Socket	Threaded	Threaded with Kit	
1/4	EPDM	1522-002	1521-002	1529-002	150 psi Non-Shock Water @ 73°F
	FKM	1532-002	1531-002	1539-002	
3/8	EPDM	1522-003	1521-003	N/A	
	FKM	1532-003	1531-003	N/A	

1: For CPVC Valves, add the letter "C" to part number listed (e.g., 1521-002C).
 2: For valves with 1/4" I.D. tubing adapters, add the letter "A" to the part number listed (e.g., 1529-002A).



LAB BALL VALVE WITH ADAPTER KIT

Valve & Adapter Kit

Kit allows multiple connection options. Adapters use O-ring seals for easy connection to threaded valve. Complete Kit includes:

- 1 — Threaded 1/4" Valve
- 2 — O-ring Sealed 1/4" MPT x Mipt Adapters
- 2 — EPDM or FKM O-rings (AS568-013 size)
- 1 — End Connector Wrench
- 2 — O-ring Sealed 1/4" MPT x 3/8" I.D. Tubing Barb Adapters - OR -
- 2 — O-ring Sealed 1/4" MPT x 1/4" I.D. Tubing Barb Adapters (Must Add "A" to Valve/Kit Part No.)

Lab Ball Valve Adapter Kit Only

Valve Size	O-ring Material	Part Number	
		PVC	CPVC
1/4	EPDM	LVKE-002	LVKE-002C
	FKM	LVKV-002	LVKV-002C

- Kit Includes:**
- 2 — O-rings
 - 1 — End Connector Wrench
 - 2 — 1/4" MPT x Mipt Adapters
 - 2 — 1/4" MPT x 3/8" I.D. Tubing Barb Adapters



Valves Technical Lab Ball Valves

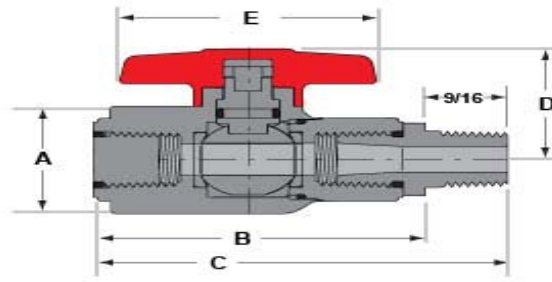

Valve with Fipt x Mipt

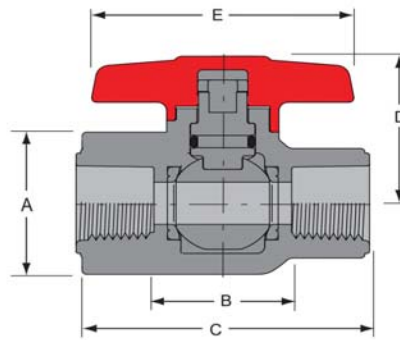

Basic Valve

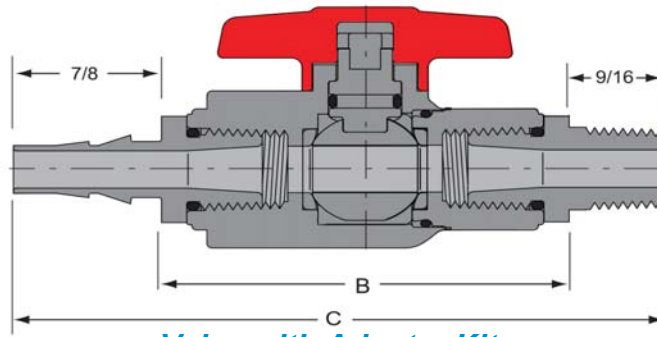

Valve with Adapter Kit

Dimensions, Weights & C_v Values

Nominal Size	Dimension Reference (inches, ± 1/16)					Approx. Wt. (Lbs.)		C _v ² Values
	A	B ¹	C	D	E	PVC	CPVC	
1/8 Fipt x Mipt	1-1/16	2-1/8	2-11/16	1-1/16	1-3/4	.10	.10	6
1/4 Fipt x Mipt	1-1/16	2-1/8	2-11/16	1-1/16	1-3/4	.12	.12	6
1/4	1-1/16	15/16	2-1/8	1-1/16	1-3/4	.10	.11	10
1/4 w/Kit	1-1/16	2-7/16	3-7/8	1-1/16	1-3/4	.14	.15	6
3/8	1-5/16	1	2-1/4	1-11/32	2	.12	.13	24

1: Valve Lay Length

2: Gallons per minute at 1 psi pressure drop. Values calculated from valve laying length, based on derivative of Hazen-Williams equation with roughness factor of C=150.

Temperature Pressure Rating

System Operating Temperature °F (°C)		73 (23)	100 (38)	110 (43)	120 (49)	130 (54)	140 (60)	150 (66)	160 (71)	170 (77)	180 (82)	190 (88)
Valve Pressure Rating psi (MPa)	PVC	150 (1.03)	124 (.85)	100 (.69)	75 (.52)	-0- (-0-)	-0- (-0-)	-0- (-0-)	-0- (-0-)	-0- (-0-)	-0- (-0-)	-0- (-0-)
	CPVC	150 (1.03)	140 (.97)	130 (.90)	120 (.83)	110 (.76)	100 (.69)	90 (.62)	80 (.55)	70 (.48)	60 (.41)	-0- (-0-)