

Valves Technical

Polypropylene Butterfly Valves

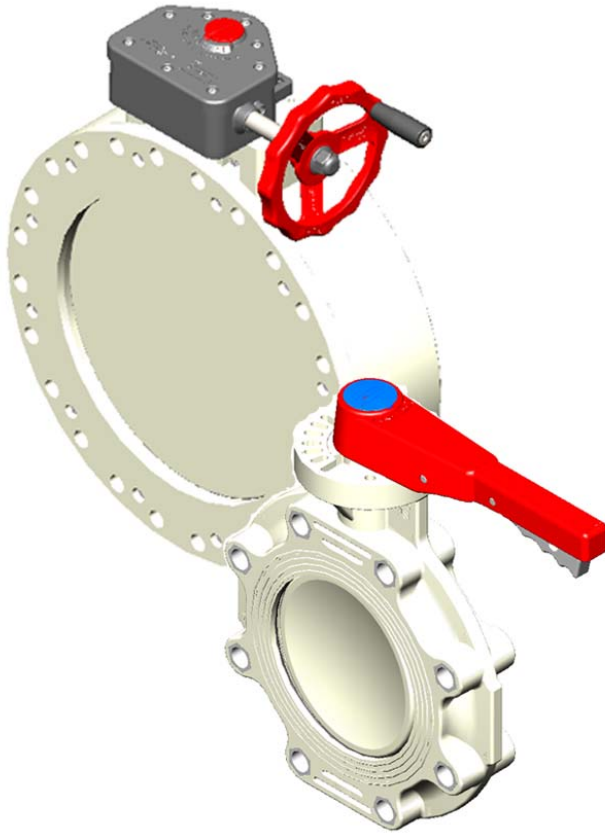

Polypropylene



Features

Spears® patented Butterfly Valve design departs from traditional liner-seat type valve to eliminate seat creep, reduce operating torque and provide positive seal-off. Broad range of chemical resistance makes Polypropylene well suited for industrial and chemical processing applications. Designed for flow control or throttling, this high-performance valve is offered with a full variety of options for greater application versatility. Available in IPS sizes 1-1/2" – 24" with custom produced 30" to 60" valves available.

- UV Stabilized Polypropylene Construction
- Special off-set Disc lifts quickly from seat to reduce wear and reduce operating torque.
- Patented Limited Contact Seat design provides free travel - eliminates seat creep, extrusion and wear. Field replaceable without full valve disassembly.
- Interlocking Body & Seat prevents wash-out or blow-out.
- Buna-N, EPDM or FKM Seat & Seals
- Solid Type 316L Stainless Steel Stem, fully isolated from process fluids
- Reversible High Impact Polypropylene Lever Handle with 7-Position stops & Built-in Lockout (standard handle on 1-1/2" – 8" valves; not available on 10" & larger valves)
- Low Profile Submersible Gear Operator Standard on 10" and larger sizes, utilizes high efficiency Acme screw with PVC or CPVC housing with high impact polypropylene handwheel and built in position indicator. Available as an option on smaller valves. Special order gear operators are available for a variety of applications.
- Pressure ratings include Dead-End Service (See Chart).
- ANSI/ASME B16.5 Class 150 Bolt Pattern

Sample Engineering Specification

All thermoplastic valves shall be Butterfly type constructed from Polypropylene, ASTM D4101. All valve seats and O-rings shall be Buna-N, EPDM or FKM. Seat shall be a non-liner type interlocked to valve body. Bolt hole pattern shall conform to ANSI/ASME B16.5 Class 150. Disc shall be offset design with fully isolated, Type 316L stainless steel stem and Type 316 stainless steel hardware. Lever operated valves shall be equipped with high impact polypropylene handle having built-in lockout capability. Gear operated valves shall be equipped with position indicator and high impact polypropylene handwheel. Valves shall be pressure rated at [see table] for water at 73°F, as manufactured by Spears® Manufacturing Company.

Material Note: UV Stabilized Polypropylene with beige pigment sizes 1-1/2" – 12" are glass reinforced, sizes 14" – 24" are not.

Optional Accessories

- PTFE Coated Stem
- Stem Extension Kit
- PTFE Seat Sleeve (through 12" size)
- Lever Handle Kit (standard on 1-1/2" – 8" valves)
- Gear Operator Kit (standard on 10" & larger valves)
- T-Handle Kit
- Speed Handle (for gear operated valves)
- Chainwheel Operator Kit (for gear operated valves)
- Positive Stem Stop (for gear operated valves)

* See "BUTTERFLY VALVE ACCESSORIES" section for details of individual products.



Valves Technical Polypropylene Butterfly Valves

Polypropylene Quick-View Valve Selection Chart

Valve Size	O-ring Material	w/Lever Handle	w/Gear Operator	Valve Only	Pressure Rating
1-1/2	Buna-N	721311-015P	Special Order	721301-015P	150 psi Non-Shock Water @ 73°F
	EPDM	722311-015P	Special Order	722301-015P	
	FKM	723311-015P	Special Order	723301-015P	
2	Buna-N	721311-020P	721321-020P	721301-020P	
	EPDM	722311-020P	722321-020P	722301-020P	
	FKM	723311-020P	723321-020P	723301-020P	
2-1/2	Buna-N	721311-025P	721321-025P	721301-025P	
	EPDM	722311-025P	722321-025P	722301-025P	
	FKM	723311-025P	723321-025P	723301-025P	
3	Buna-N	721311-030P	721321-030P	721301-030P	
	EPDM	722311-030P	722321-030P	722301-030P	
	FKM	723311-030P	723321-030P	723301-030P	
4	Buna-N	721311-040P	721321-040P	721301-040P	
	EPDM	722311-040P	722321-040P	722301-040P	
	FKM	723311-040P	723321-040P	723301-040P	
6	Buna-N	721311-060P	721321-060P	721301-060P	
	EPDM	722311-060P	722321-060P	722301-060P	
	FKM	723311-060P	723321-060P	723301-060P	
8	Buna-N	721311-080P	721321-080P	721301-080P	
	EPDM	722311-080P	722321-080P	722301-080P	
	FKM	723311-080P	723321-080P	723301-080P	
10	Buna-N	10" and Larger not available with Lever Handle	721321-100P	721301-100P	
	EPDM		722321-100P	722301-100P	
	FKM		723321-100P	723301-100P	
12	Buna-N		721321-120P	721301-120P	
	EPDM		722321-120P	722301-120P	
	FKM		723321-120P	723301-120P	
14	Buna-N		—	—	
	EPDM		722321-140P	722301-140P	
	FKM		723321-140P	723301-140P	
18	Buna-N		—	—	
	EPDM		722321-180P	722301-180P	
	FKM		723321-180P	723301-180P	
20	Buna-N		—	—	
	EPDM		722321-200P	722301-200P	
	FKM		723321-200P	723301-200P	
24	Buna-N		—	—	
	EPDM		722321-240P	722301-240P	
	FKM		723321-240P	723301-240P	

Note: 30" - 60" Polypropylene Butterfly Valves produced to order.

Temperature Pressure Rating

System Operating Temperature °F (°C)		100 (38)	110 (43)	120 (49)	130 (54)	140 (60)	150 (66)	160 (71)	170 (77)	180 (82)	190 (88)
Valve Pressure Rating psi (MPa)	1-1/2"-12"	150 (1.03)	105 (.72)	90 (.62)	80 (.55)	65 (.45)	50 (.34)	45 (.31)	30 (.21)	20 (.14)	-0-
	14"	100 (.69)	70 (.48)	60 (.41)	53 (.37)	43 (.26)	33 (.23)	30 (.21)	20 (.14)	13 (.09)	-0-
	18"	70 (.48)	49 (.34)	42 (.29)	37 (.26)	30 (.21)	23 (.16)	21 (.14)	14 (.10)	9 (.06)	-0-
	20"-24"	50 (.34)	35 (.24)	30 (.21)	27 (.19)	22 (.15)	17 (.12)	15 (.10)	10 (.07)	7 (.05)	-0-