



Basic Valve

Features - PVC Gray

Backwater Valves are designed to prevent backflow in numerous applications where easy service access for maintenance and cleaning is needed. Excellent for use in sanitary or storm sewer drainage systems to prevent waste back up due to inadequate drainage, for balancing multi-level ponds, aquaculture features or storage tank systems, and many other applications. Spears® Backwater Valve has been engineered for improved function and easier service, especially in buried service with use of optional Service-Access Extension Kit.

- All PVC Construction with EPDM Flapper Seal
- Threaded Top Plug for Convenient Service
- Simple Snap-In Internal Flapper Assembly for Easy Replacement
- Optional Factory Assembled Service-Access Extension Kits - External Housing with Internal Extension for Convenient Removal, Inspection or Replacement
- Optional Extension Components Kits for Assembly with User-Supplied Pipe
- Available in Sizes 2", 3", 4", 6", 8" and 10" with Socket Ends
- Direct Connection to ASTM D 2665 PVC DWV or other IPS size pipe. Spears® IPS x Sewer Adapters available for Connection to ASTM 3034 Sewer
- Conforms to ASME/ANSI A112.14.1 for Backwater Valves
- Pressure Rated to 43 psi (100 feet of head) @ 73°F



Valve with Extension Kit

Sample Engineering Specification

All thermoplastic valves shall be Backwater type constructed from PVC Type I, ASTM D 1784 Cell Classification 12454. All Valve Seats shall be EPDM. All valves shall have external Arrow Flow Indicator. All valves shall be pressure rated to 43 psi (100 feet of Head) for water @ 73°F as manufactured by Spears® Manufacturing Company.

PVC Service-Access Extension Kit Options:

Available as a complete unit, with or without valve, factory assembled to internal flap assembly, extension pipe, and external extension housing with top access adapter in convenient increments of 12", 16", 20", 24", 36", and 48" (measured from top of valve to top of extension). All extension kits can be cut shorter in the field for custom fits. Also available as Extension Components Kits, with or without valve for assembly with user-supplied Class 125 or Schedule 40 pipe. Kits without valve require use of existing valve top Access Plug, all kits require solvent cement assembly to valve. Contact Spears® for MSRP on custom cut lengths.

Quick-View Backwater Valve Selection Chart, Standard Valve

Valve Size	Seat Material	PVC Material	Pressure Rating
		Socket	
2	EPDM	S275P	43 psi (100 feet of Head)
3	EPDM	S375P	
4	EPDM	S475P	
6	EPDM	S675P	
8	EPDM	S875P	
10	EPDM	S1075P	
12	EPDM	S1275P	

Quick View Extension Components Kit Options

Extension Adapters and Flap Assembly with or without valve. Must be assembled with user-supplied Class 125 or Schedule 40 Pipe.

Valve Size	Socket Valve With Extension Component Kit	Extension Component Kit Only	Pressure Rating
2	S275P-AK	S275P-ECK	43 psi (100 feet of head)
3	S375P-AK	S375P-ECK	
4	S475P-AK	S475P-ECK	
6	S675P-AK	S675P-ECK	
8	S875P-AK	S875P-ECK	
10	S1075P-AK	S1075P-ECK	



Valves Technical Industrial Backwater Valves

Quick-View Backwater Valves with Extension Kit to Premade Lengths

Socket Valve with complete Extension Assembly in precut lengths.

Valve x Extension Size ¹	Socket Valve With Extension	Valve x Extension Size ¹	Socket Valve With Extension	Pressure Rating
2 x 12HT	S275P-120	4 x 12HT	S475P-120	43 psi (100 feet of head)
2 x 16HT	S273P-160	4 x 16HT	S473P-160	
2 x 20HT	S275P-200	4 x 20HT	S475P-200	
2 x 24HT	S275P-240	4 x 24HT	S475P-240	
2 x 36HT	S275P-360	4 x 36HT	S475P-360	
2 x 48HT	S275P-480	4 x 48HT	S475P-480	
3 x 12HT	S375P-120	6 x 12HT	S675P-120	
3 x 16HT	S373P-160	6 x 16HT	S673P-160	
3 x 20HT	S375P-200	6 x 20HT	S675P-200	
3 x 24HT	S375P-240	6 x 24HT	S675P-240	
3 x 36HT	S375P-360	6 x 36HT	S675P-360	
3 x 48HT	S375P-480	6 x 48HT	S675P-480	

¹ - Size designates nominal valve size x extension height (HT-top of valve to top of extension, inches).

Quick-View Service Access Extension Kit Only In Premade Lengths (valve not included)

Extension Assembly in precut lengths. Use existing valve top Access Plug.

Size ¹	Premade Extension	Size ¹	Premade Extension	Pressure Rating
2 x 12HT	SAEK-020-120	4 x 12HT	SAEK-040-120	43 psi (100 feet of head)
2 x 16HT	SAEK-020-160	4 x 16HT	SAEK-040-160	
2 x 20HT	SAEK-020-200	4 x 20HT	SAEK-040-200	
2 x 24HT	SAEK-020-240	4 x 24HT	SAEK-040-240	
2 x 36HT	SAEK-020-360	4 x 36HT	SAEK-040-360	
2 x 48HT	SAEK-020-480	4 x 48HT	SAEK-040-480	
3 x 12HT	SAEK-030-120	6 x 12HT	SAEK-060-120	
3 x 16HT	SAEK-030-160	6 x 16HT	SAEK-060-160	
3 x 20HT	SAEK-030-200	6 x 20HT	SAEK-060-200	
3 x 24HT	SAEK-030-240	6 x 24HT	SAEK-060-240	
3 x 36HT	SAEK-030-360	6 x 36HT	SAEK-060-360	
3 x 48HT	SAEK-030-480	6 x 48HT	SAEK-060-480	

¹ - Size designates nominal valve size x extension height (HT-top of valve to top of extension, inches). All extension kits can be cut shorter in the field for custom fits.

STANDARD VALVE

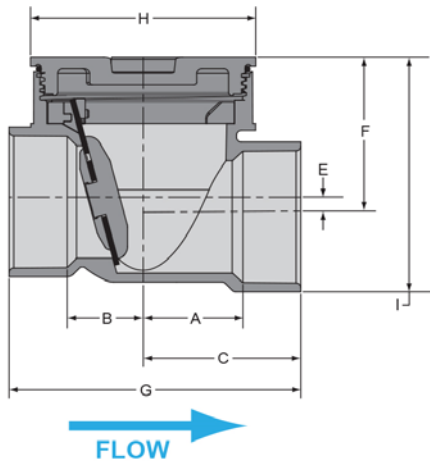

Standard Valve Dimensions

Size	A	B	C	E	F	G	H	I
2	1-13/16	1-3/4	2-5/8	5/16	3-1/4	5-9/32	4-3/16	4-9/16
3	2-5/8	2	4-3/16	13/32	4-1/8	7-3/4	6	6-1/8
4	3-5/8	3-3/4	5-7/16	23/32	5-7/16	10-15/16	8-1/4	7-15/16
6	4-3/4	4-5/8	7-3/4	13/16	7-3/16	15-3/8	11-1/4	10-13/16
8	8-1/8	8-1/8	12-1/8	3/4	13-1/2	24-1/4	15-7/8	20-7/8
10	9-1/2	9-1/2	14-1/2	-	15-3/16	29	18	23-1/4

VALVE WITH EXTENSION KIT

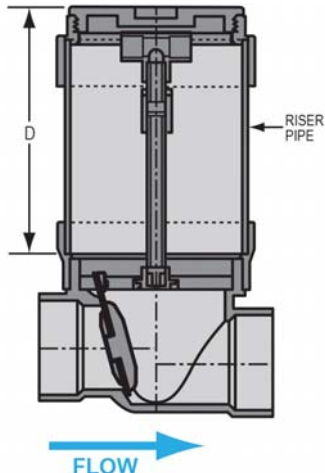

Valve with Extension Kit Dimensions (Inches)

HEIGHT-D
12
16
20
24
36
48
D = Top of plug Standard Valve to top of plug with Extension