



PVC Compression Couplings

Multi-Featured Design • Industrial PVC Gray • Easy-Thread Compression Nut • Converts to Spigot Coupling



Excellent for quick connections, system modifications and repairs. Spears® redesigned Compression Coupling provides improved function, broader application and increased versatility. Standard PVC White units have been a long standing choice for Irrigation and Pool & Spa applications. PVC Gray Industrial unit provides broader range of Industrial and Chemical processing applications. Compression nut features strong Buttress threads engineered for easier tightening during installation. New body design has pipe-spigot dimensions allowing unit to be used to convert a socket fitting to a compression fitting. Available in IPS sizes 1/2" through 6".

- PVC Gray Industrial Construction**
 Heavy bodied, chemical and corrosion resistant PVC Gray Industrial units provide for a broad range of applications.
- Elastomer Compression Gaskets**
 PVC Gray Industrial unit is offered with elastomer gaskets.
- Strong, Buttress Threaded Compression Nuts**
 Revised Nut design features increased strength of Buttress thread plus greater ease of Nut installation onto Body. Superior to standard pipe or square-cut ACME type threads.
- Full Service Pressure Rating**
 1/2" - 2 1/2" = 200 psi, 3" - 6" = 150 psi internal pressure rating @ 73°F.
- NSF® Certified for Potable Water Use**
 Compression Couplings are certified by NSF International for use in potable water systems.
- Spigot Conversion Capability**
 Convert socket-outlet plastic pipe fitting to compression-outlet fitting. Simply cut the Compression Coupling in half next to center holding ribs. Body now functions as a spigot for solvent weld attachment to fitting socket (for Compression Couplings through 2" only).

Compression Coupling, PVC Gray

Elastomer Gasket

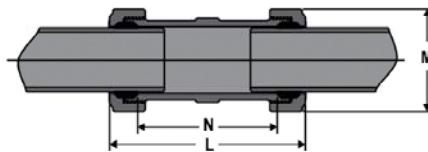

Part Number	Size	L	M	N	Approx. Wt. (Lbs.)
S110-05G	1/2	5	1-13/16	3-3/8	.18
S110-07G	3/4	5-3/8	2-1/8	3-9/16	.26
S110-10G	1	5-3/4	2-1/2	3-3/4	.41
S110-12G	1-1/4	6	2-15/16	4-3/32	.51
S110-15G	1-1/2	6-3/4	3-5/16	4-21/32	.82
S110-20G	2	7-9/32	3-15/16	5-3/32	1.21
S110-25G	2-1/2	8-7/8	4-15/16	5-7/8	2.61
S110-30G	3	9-5/16	5-1/2	6-3/16	3.22
S110-40G	4	11-1/2	6-3/4	7-3/4	5.70
S110-60G	6	11-3/4	9-3/8	7-7/8	9.21



Schedule 80 PVC Technical
Compression Couplings Dimensions & Information

Easy Installation

Spears® Compression Couplings easily install by simply sliding nut over pipe, slip on gasket, then insert into body and tighten nuts.

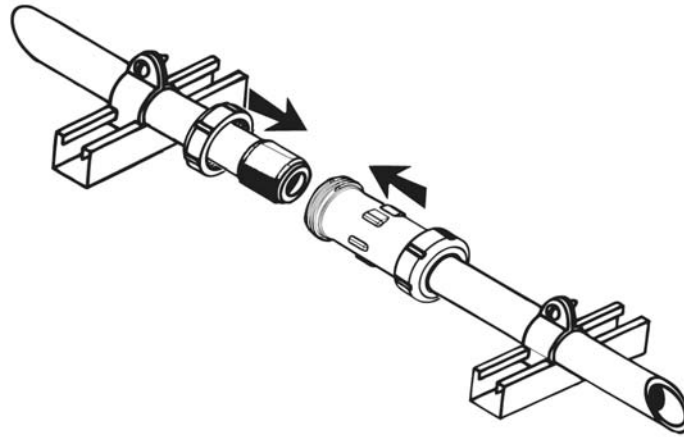

Convert Fittings to Compression Outlet

Socket type fittings 3/4" through 2-1/2" can be easily converted to compression outlets sizes 1/2" through 2" by simply cutting the Compression Coupling at the center holding ribs and solvent welding the spigot body into a fitting socket.

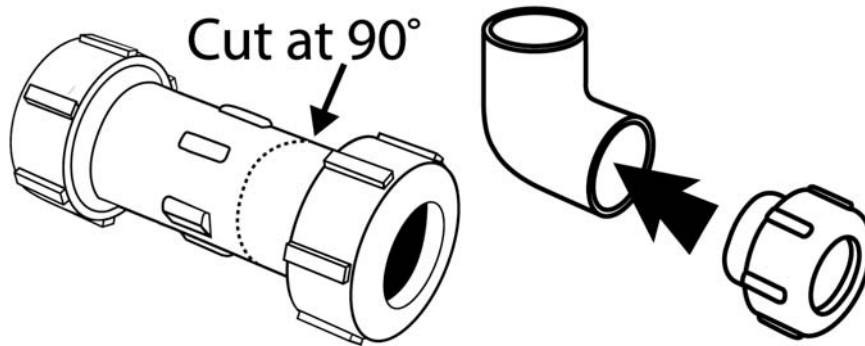

Compression Coupling Size (in.)	Body Spigot Size (in.)
1/2	3/4
3/4	1
1	1-1/4
1-1/4	1-1/2
1-1/2	2
2	2-1/2
2-1/2	3

Important Installation Note

WARNING: The compression joints provide a positive seal but do not restrain pipe from thrusts and movement under pressure. Use of compression joint requires blocking connecting pipe to prevent any movement. Failure to do so can result in system failure or severe personal injury. Use in cold water/fluid applications only.