



Hot-Tap Saddles



ENGINEERING GUIDE

Contact Spears® for any Information not found.

Allows Connection to Existing Pipelines Under Pressure



Specially designed tapping saddle allows pipe branch connection to pressurized "Hot" lines without system shut-down.

- Industrial Grade Bolt-on Saddle with EPDM or FKM O-ring Seals and Choice of Zinc Plated Steel or Type 316 Stainless Steel Hardware.
- Built-in Brass or Stainless Steel Cutter Easily Cuts Hole in PVC, CPVC, HDPE and PP Pipe. Special Design Captures and Retains Coupon from Hole.
- Pressure Rated up to 235 psi @ 73°F.
- Available to fit IPS Pipe 2" through 8" with Versatile 3/4" Socket - 1" Spigot Combination Branch Outlet or 1-1/2" Socket - 2" Spigot Combination Branch Outlet

TECHNICAL DATA

Maximum Service Temperatures		Pressure Rating @ 73°F	
PVC	140°F	2" - 4"	235 psi
CPVC	200°F	6"	200 psi
Note: Elevated service temperatures require system pressure de-rating.		8"	150 psi

Note: Some leakage is possible during the tapping process, therefore "hot-taps" are not recommended for corrosive or dangerous fluid medium.

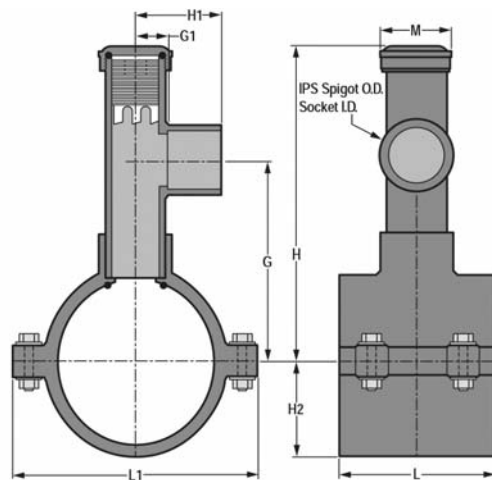

Dimensions - EPDM Saddle x Socket (Spigot) Zinc Plated Bolts

Part Number	Size	G	G1	H	H 1	H2	L	L1	M
HT2-248C	2 x 3/4 (1)	3-9/16	1	6-3/16	2	1-1/2	2-7/16	3-1/2	2
HT2-251C	2 x 1-1/2 (2)	4-9/16	1-1/4	8-15/16	2-11/16	1-1/2	2-7/16	3-1/2	2-7/8
HT2-288C	2-1/2 x 3/4 (1)	3-15/16	1	6-9/16	2	1-3/4	4-1/8	4-1/8	2
HT2-291C	2-1/2 x 1-1/2 (2)	4-13/16	1-1/4	9-3/16	2-11/16	1-3/4	4-1/8	4-1/8	2-7/8
HT2-334C	3 x 3/4 (1)	4-1/6	1	6-11/16	2	2	3	4-3/4	2
HT2-337C	3 x 1-1/2 (2)	5-1/4	1-1/4	9-5/8	2-11/16	2	4-1/8	4-3/4	2-7/8
HT2-416C	4 x 3/4 (1)	4-11/16	1	7-5/16	2	2-5/8	3	5-13/16	2
HT2-419C	4 x 1-1/2 (2)	5-13/16	1-1/4	10-3/16	2-11/16	2-5/8	4-1/8	5-13/16	2-7/8
HT2-524C	6 x 3/4 (1)	6	1	8-5/8	2	3-7/8	3	8-1/8	2
HT2-527C	6 x 1-1/2 (2)	7-1/8	1-1/4	11-1/2	2-11/16	3-7/8	4-1/8	8-1/8	2-7/8
HT2-574C	8 x 3/4 (1)	7-1/4	1	9-7/8	2	4-7/8	8-1/2	10-1/8	2
HT2-577C	8 x 1-1/2 (2)	8-9/16	1-1/4	12-9/16	2-11/16	4-7/8	8-1/2	10-1/8	2-7/8

EPDM Saddle x Socket (Spigot) SS316 Bolts, Add The Letter "S" Before The Dash. e.g. Part Number HT2**S**-248C = 2x3/4 CPVC Bolt On Saddle, EPDM O-ring, Stainless Steel Hardware. FKM Saddle x Socket (Spigot) Zinc Plated Bolts, Add The Number "3" Before The Dash. e.g. Part Number HT**3**-248C = 2x3/4 CPVC Bolt On Saddle, FKM O-ring, Zinc Plated Hardware. FKM Saddle x Socket (Spigot) SS316 Bolts, Add "3S" Before The Dash. e.g. Part Number HT**3S**-248C = 2x3/4 CPVC Bolt On Saddle, FKM O-ring, Stainless Steel Hardware. EPDM with Stainless Steel Cutter & Bolts, Add "S2S" Before The Dash. e.g. Part Number HT**S2S**-248C = 2x3/4 CPVC Bolt On Saddle, EPDM O-ring, Stainless Steel Cutter & Hardware. FKM with Stainless Steel Cutter & Bolts, Add "S3S" Before The Dash. e.g. Part Number HT**S3S**-248C = 2x3/4 CPVC Bolt On Saddle, FKM O-ring, Stainless Steel Cutter & Hardware.



Allows Connection to Existing Pipelines Under Pressure



Specially designed tapping saddle allows pipe branch connection to pressurized "Hot" lines without system shut-down.

- Industrial Grade Bolt-on Saddle with EPDM or FKM O-ring Seals and Choice of Zinc Plated Steel or Type 316 Stainless Steel Hardware.
- Built-in Brass or Stainless Steel Cutter Easily Cuts Hole in PVC, CPVC, HDPE and PP Pipe. Special Design Captures and Retains Coupon from Hole.
- Pressure Rated up to 235 psi @ 73°F.
- Available to fit IPS Pipe 2" through 8" with Versatile 3/4" Socket - 1" Spigot Combination Branch Outlet or 1-1/2" Socket - 2" Spigot Combination Branch Outlet

TECHNICAL DATA

Maximum Service Temperatures

PVC	140°F
CPVC	200°F

Note: Elevated service temperatures require system pressure de-rating.

Pressure Rating @ 73°F

2" - 4"	235 psi
6"	200 psi
8"	150 psi

Note: Some leakage is possible during the tapping process, therefore "hot-taps" are not recommended for corrosive or dangerous fluid medium.

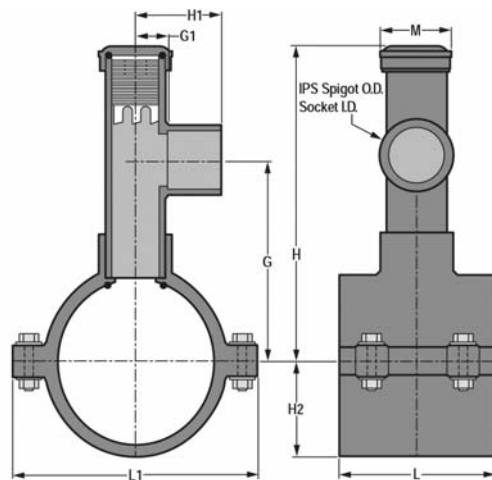

Dimensions - EPDM Saddle x Socket (Spigot) Zinc Plated Bolts

Part Number	Size	G	G1	H	H 1	H2	L	L1	M
HT2-248C	2 x 3/4 (1)	3-9/16	1	6-3/16	2	1-1/2	2-7/16	3-1/2	2
HT2-251C	2 x 1-1/2 (2)	4-9/16	1-1/4	8-15/16	2-11/16	1-1/2	2-7/16	3-1/2	2-7/8
HT2-288C	2-1/2 x 3/4 (1)	3-15/16	1	6-9/16	2	1-3/4	4-1/8	4-1/8	2
HT2-291C	2-1/2 x 1-1/2 (2)	4-13/16	1-1/4	9-3/16	2-11/16	1-3/4	4-1/8	4-1/8	2-7/8
HT2-334C	3 x 3/4 (1)	4-1/6	1	6-11/16	2	2	3	4-3/4	2
HT2-337C	3 x 1-1/2 (2)	5-1/4	1-1/4	9-5/8	2-11/16	2	4-1/8	4-3/4	2-7/8
HT2-416C	4 x 3/4 (1)	4-11/16	1	7-5/16	2	2-5/8	3	5-13/16	2
HT2-419C	4 x 1-1/2 (2)	5-13/16	1-1/4	10-3/16	2-11/16	2-5/8	4-1/8	5-13/16	2-7/8
HT2-524C	6 x 3/4 (1)	6	1	8-5/8	2	3-7/8	3	8-1/8	2
HT2-527C	6 x 1-1/2 (2)	7-1/8	1-1/4	11-1/2	2-11/16	3-7/8	4-1/8	8-1/8	2-7/8
HT2-574C	8 x 3/4 (1)	7-1/4	1	9-7/8	2	4-7/8	8-1/2	10-1/8	2
HT2-577C	8 x 1-1/2 (2)	8-9/16	1-1/4	12-9/16	2-11/16	4-7/8	8-1/2	10-1/8	2-7/8

EPDM Saddle x Socket (Spigot) SS316 Bolts, Add The Letter "S" Before The Dash. e.g. Part Number HT2**S**-248C = 2x3/4 CPVC Bolt On Saddle, EPDM O-ring, Stainless Steel Hardware. FKM Saddle x Socket (Spigot) Zinc Plated Bolts, Add The Number "3" Before The Dash. e.g. Part Number HT3-248C = 2x3/4 CPVC Bolt On Saddle, FKM O-ring, Zinc Plated Hardware. FKM Saddle x Socket (Spigot) SS316 Bolts, Add "3S" Before The Dash. e.g. Part Number HT3**S**-248C = 2x3/4 CPVC Bolt On Saddle, FKM O-ring, Stainless Steel Hardware. EPDM with Stainless Steel Cutter & Bolts, Add "S2S" Before The Dash. e.g. Part Number HT**S2S**-248C = 2x3/4 CPVC Bolt On Saddle, EPDM O-ring, Stainless Steel Cutter & Hardware. FKM with Stainless Steel Cutter & Bolts, Add "S3S" Before The Dash. e.g. Part Number HT**S3S**-248C = 2x3/4 CPVC Bolt On Saddle, FKM O-ring, Stainless Steel Cutter & Hardware.

Basic Installation

Hot-Tap Saddles are designed for adding branch connections to piping systems under live ("hot") pressure. Hot-Tap Saddle branch outlets are either 3/4" socket (with 1" Spigot O.D.) or 1-1/2" socket (with 2" Spigot O.D.) in saddle sizes 2" through 8" to fit IPS pipe using a built-in O-ring seal. Internal cutter is operated using conventional ratchet and drive extension and permanently retains coupon cut from pipe. Maximum operating pressure at 73°F is 235 psi for saddle sizes 2" - 4", 200 psi for 6" saddles & 150 psi for 8".

SEE PRODUCT INSTALLATION INSTRUCTION FOR DETAILS

COMPONENTS

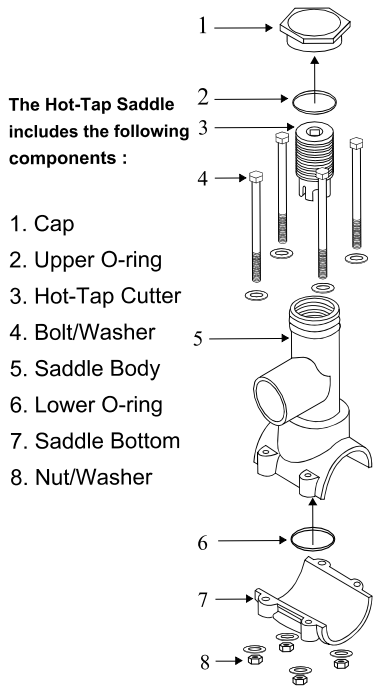

STEP 3 Cement Branch Take-off

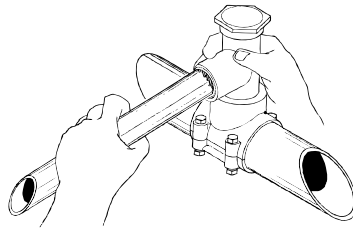

Allow joint to cure.

STEP 4 Remove Cap

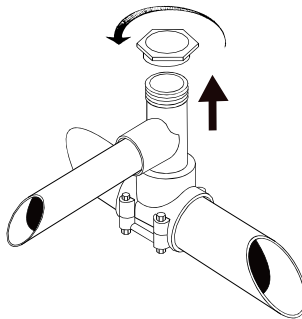

STEP 6 Back-off Cutter to Top to Open Flow

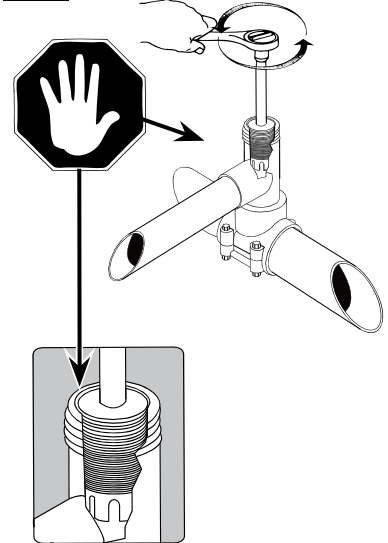

STEP 1 Assemble on Pipe

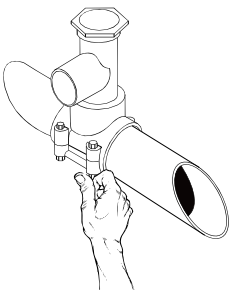

STEP 5 Tap to Required Depth

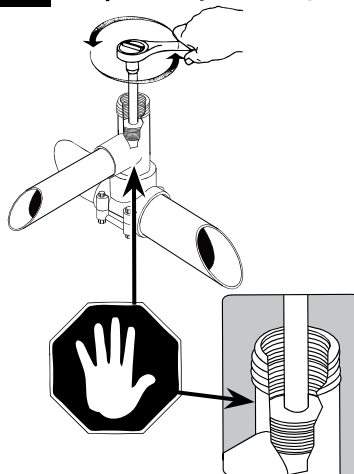

STEP 7 Reinstall Opening Sealed Cap



STEP 2 Torque to Specifications

