



Pipe & Hangers Technical
Spears® PVC & CPVC Duct

PVC & CPVC Corrosion Resistant Duct

PVC & CPVC DUCT

Spears® PVC and CPVC seamless round extruded duct is available in 6" through 24" diameters with cold-rolled fabricated duct available in 26" through 48". Excellent for industrial and institutional corrosive fume exhaust.

Physical Properties

Spears® PVC and CPVC Duct Systems exhibit high tensile strength, various temperature ranges, low thermal conductivity, good electrical properties and excellent chemical/corrosion resistance to a variety of aggressive substances. Its physical properties allow it to perform great in aggressive environments that are not suitable for other types of materials, plus its lightweight provides construction advantages, ease of fabrication and at a lower cost.

PVC & CPVC Duct Physical Properties

GENERAL	VALUE		TEST METHOD
	PVC Duct	CPVC Duct	
Cell Classification	12454	23447	ASTM D 1784
Maximum Service Temp.	140°F	200°F	---
Color	Dark Gray	Medium Gray	---
Specific Gravity (g/cu.cm @ 73°F)	1.40 +/-0.02	1.53 +/-0.02	ASTM D 792
Water Absorption % increase 24 hrs @ 25°C	0.05	0.03	ASTM D 570
Hardness: Rockwell	110 - 120	117	ASTM D 785
Poisson's Ratio @ 73°F	0.410	0.386	---
Hazen-Williams Factor	C = 150	C = 150	---
MECHANICAL			
Tensile Strength, psi @ 73°F	7,450	7,600	ASTM D 638
Tensile Modulus of Elasticity, psi @ 73°F	420,000	370,000	ASTM D 638
Flexural Strength, psi @ 73°F	14,450	12,500	ASTM D 790
Flexural Modulus, psi @ 73°F	360,000	360,000	ASTM D 790
Compressive Strength, psi @ 73°F	9,600	10,000	ASTM D 695
Compressive Modulus, psi @ 73°F	---	196,000	ASTM D 695
Izod Impact, notched ft-lb/in @ 73°F	0.75	2.6	ASTM D 256
THERMAL			
Coefficient of Linear Expansion (in/in°F)	2.9 x 10 ⁻⁵	3.2 x 10 ⁻⁵	ASTM D 696
Coefficient of Thermal Conductivity	3.5 x 10 ⁻⁴	3.27 x 10 ⁻⁴	ASTM C 177
BTU • inches/hour • Ft. ²	1.02	0.95	---
Watt/mK	0.147	0.137	---
Heat Deflection Temperature Under Load (264psi - annealed)	170	228°	ASTM D 648
ELECTRICAL			
Dielectric Strength, volts/mil	1,413	1,250	ASTM D 149
Dielectric Constant, 60Hz @ 30°F	3.70	3.70	ASTM D 150
Volume Resistivity, ohm/cm @ 95°C	1.2 x 10 ¹²	3.4 x 10 ¹⁵	ASTM D 257
Power Factor	---	0.007%	ASTM D 150
PVC & CPVC Pipe is non-electrolytic			
FIRE PERFORMANCE			
Flammability Rating	V-0	V-0, 5VB, 5VA	UL-94
Flame Spread Index	<10	<10	ASTM E 162
Flame Spread	---	<25	ASTM E-84/UR 723
	0-25	<25	ULC S102.2
Smoke Generation	---	≤50	ASTM E-84/UR 723
	80-225	<50	ULC S102.2
Flash Ignition Temp.	730°F	900°F	---
Average Time of Burning (sec.)	<5	<5	ASTM D 635
Average Extent of Burning (mm)	<10	<10	ASTM D 635
Burning Rate (in/min)	Self Extinguishing	Self Extinguishing	---
Softening Starts (approx.)	250°F	295°F	---
Material Becomes Viscous	350°F	395°F	---
Material Carbonizes	425°F/td>	450°F	---
Limiting Oxygen Index (LOI)	---	60	ASTM D 2863



PVC & CPVC Corrosion Resistant Duct

Materials

PVC

Spears® PVC duct is extruded seamless round or cold-rolled fabricated from dark-gray-colored Type I, Grade I PVC material having a Cell Classification of 12454 per ASTM D 1784 (PVC 1120), and has a maximum service temperature of 140°F. Spears® PVC duct is chemically resistant to most acids, bases, salts, aliphatic solutions, oxidants, and halogens. Unlike metallic materials, vapor phase or liquid-vapor phase corrosion is generally less aggressive with thermoplastics than the liquid phase corrosion. When in question, testing must be conducted under actual use conditions to verify compatibility. [Detailed chemical resistance data](#) should be referenced for proper material selection.

CPVC

Spears® CPVC Duct is extruded seamless round or cold-rolled fabricated from a light-gray-colored CPVC material with a Cell Classification of 23437 per ASTM D 1784 and has a maximum service temperature of 200°F for hot fumes. In addition, CPVC duct also has excellent fire performance properties. It has been subjected to large-scale testing having a flame spread rating of < 25, and a smoke development rating of < 50 making it ideal for use in critical areas (such as air plenums) where fire performance issues are of a concern. Spears® CPVC Duct is chemically resistant to most acids, bases, salts, aliphatic solutions, oxidants, and halogens. Although the chemical resistance of PVC and CPVC are similar, they are not the same. Detailed chemical resistance data should be referenced for proper material selection.

Flammability

Spears® duct has excellent flammability properties and will not independently support combustion - it will not burn unless a flame is constantly applied and will stop burning once the flame is removed. Spears® CPVC duct has improved fire performance properties over PVC with low flame-spread and smoke-generation properties. Refer to the Fire Performance section of the PVC & CPVC Duct Physical Properties table.

Dimensions

Spears® seamless round duct is extruded in Iron Pipe Size (IPS) dimensions with large internal flow areas that can easily be adapted to other common IPS fittings, reducing fabrication and installation time.

PVC Extruded Round Duct Dimensions

Size (in.)	AVG. O.D.	AVG. O.D.TOL.	O of R TOL.	MIN. Wall	AVG. Wall	MAX. Wall	WT(lbs.) Per Ft.
6 x 1/8	6.625	+/- .020	+/- .050	0.105	0.122	0.140	1.530
6	6.625	+/- .020	+/- .050	0.172	0.187	0.202	2.275
7	7.375	+/- .020	+/- .050	0.172	0.187	0.202	2.534
8	8.625	+/- .020	+/- .075	0.172	0.187	0.202	2.982
9	9.375	+/- .025	+/- .075	0.172	0.187	0.202	3.239
10	10.750	+/- .025	+/- .075	0.172	0.187	0.202	3.733
11	11.375	+/- .025	+/- .075	0.172	0.187	0.202	3.944
12	12.750	+/- .025	+/- .075	0.172	0.187	0.202	4.440
14	14.000	+/- .030	+/- .075	0.172	0.187	0.202	4.884
16	16.000	+/- .030	+/- .075	0.172	0.187	0.202	5.586
18	18.000	+/- .040	+/- .080	0.172	0.187	0.202	6.750
20	20.000	+/- .070	+/- .140	0.199	0.219	0.239	8.144
24	24.000	+/- .090	+/- .180	0.230	0.250	0.270	11.163

O of R = Out of Roundness Factor at time of extrusion *I.D. Sizes

CPVC Extruded Round Duct Dimensions

Size (in.)	AVG. O.D.	AVG. O.D.TOL.	O of R TOL.	MIN. Wall	AVG. Wall	MAX. Wall	WT(lbs.) Per Ft.
6	6.625	+/- .020	+/- .050	0.172	0.187	0.202	2.555
8	8.625	+/- .020	+/- .075	0.172	0.187	0.202	3.349
10	10.750	+/- .025	+/- .075	0.172	0.187	0.202	4.192
12	12.750	+/- .025	+/- .075	0.172	0.187	0.202	4.986
14	14.000	+/- .030	+/- .075	0.172	0.187	0.202	5.485
16	16.000	+/- .030	+/- .075	0.172	0.187	0.202	6.273
18	18.000	+/- .040	+/- .080	0.172	0.187	0.202	7.580
20	20.000	+/- .070	+/- .140	0.199	0.219	0.239	9.146
24	24.000	+/- .090	+/- .180	0.230	0.250	0.270	12.536

O of R = Out of Roundness Factor at time of extrusion

Large Diameter Duct

Spears® fabricated round duct (26" & larger diameter) is cold rolled from extruded PVC or CPVC sheet material. The seam is thermal fused utilizing computerized welding. The sheet edges are heated and pressed together pneumatically achieving 100% weld strength using no filler rod. Wall thickness is 3/16" for sizes up to 32" diameter. Above 32" diameter, 1/4" material will be used, unless otherwise specified. Cold rolled duct is produced in 4' lengths. Large duct fittings can be fabricated to order. Contact Spears® with requirements for additional information.

System Components

Fittings fabricated from Spears® duct are available in most configurations. All duct fittings, fume hoods, fume scrubbers, fans, blast gates and other system components should be fabricated from PVC/CPVC sheet or duct of the same wall thickness and from materials that conform to ASTM D 1784.

Storage and Handling

Although Spears® duct is tough and corrosion resistant, it should not be dropped nor have objects dropped on it. Reasonable care and common sense should be used, including during transport and storage to prevent distortion. Duct should not be stored close to heat-producing sources, subjected to external loads (i.e., heavy objects, over strapping, etc.) or over stacked when stored. When stored outdoors, Spears® duct must be covered with an opaque material to reduce the risk of heat absorption and discoloration. Prior to use, inspect duct for scratches, splits or gouges. If found, these sections must be cut out and discarded.



Product Ratings and Capability

Spears® PVC and CPVC duct is excellent for harsh environments and has been used at various negative and positive pressure conditions in diverse laboratory and industrial applications product ratings will vary according to size and temperature. The ratings in the following tables are based on a 1.5:1 safety factor.

Negative Pressure Ratings

PVC MAX. Internal Negative Pressure Rating Inches of Water @ Various Temperatures °F

Size (in.)	TEMPERATURE °F							
	73	80	90	100	110	120	130	140
6 x 1/8	115	101	86	71	59	46	36	25
6	415	365	311	257	212	166	129	91
7	301	265	226	187	153	120	93	66
8	188	166	141	117	96	75	58	41
9	146	129	110	91	75	59	45	32
10	97	85	73	6	50	39	30	21
11	82	72	61	51	42	33	25	18
12	58	51	44	36	30	23	18	13
14	44	39	33	27	22	18	14	10
16	29	26	22	18	15	12	9	6
18	21	18	16	13	11	8	6	4
20	24	21	18	15	12	10	7	5
24	21	18	16	13	11	8	6	4

PSI = Inches of Water x .0361; Inches of Mercury = Inches of Water x .07355 MAX. Internal Positive Pressure Rating

CPVC MAX. Internal Negative Pressure Rating Inches of Water @ Various Temperatures °F

Size (in.)	TEMPERATURE °F						
	73	100	120	140	160	180	200
6	426	371	316	263	208	153	98
8	193	168	143	118	93	70	45
10	100	86	73	60	48	35	23
12	60	51	43	36	28	20	13
14	45	38	33	26	21	15	10
16	30	26	21	18	13	10	6
18	26	23	20	16	13	10	6
20	28	25	21	16	13	10	6
24	20	18	15	13	10	6	3

PSI = Inches of Water x .0361; Inches of Mercury = Inches of Water x .07355

Positive Pressure

PVC and CPVC duct can endure greater levels of positive internal pressure than negative internal pressure. The following tables show the maximum recommended internal positive pressure rating in PSI for PVC and CPVC duct at various temperatures.

Positive Pressure Ratings

PVC MAX. Internal Positive Pressure Rating PSI @ Various Temperatures °F

Size (in.)	TEMPERATURE °F							
	73	80	90	100	110	120	130	140
6 x 1/8	42	37	31	26	21	17	13	9
6	70	62	52	43	35	28	22	15
7	64	56	48	40	32	25	20	14
8	53	47	40	33	27	21	16	12
9	74	65	55	46	38	29	23	16
10	43	39	32	27	22	17	13	9
11	61	53	46	38	31	24	19	13
12	36	32	27	22	18	14	11	8
14	33	29	25	20	17	13	10	7
16	28	25	21	17	14	11	9	6
18	25	22	19	15	13	10	8	5
20	26	23	20	16	13	10	8	6
24	25	22	19	15	13	10	8	5

CPVC MAX. Internal Positive Pressure Rating PSI @ Various Temperatures °F

Size (in.)	TEMPERATURE °F						
	73	100	120	140	160	180	200
6	70	56	45	35	26	16	13
8	53	43	33	26	20	13	10
10	43	35	28	21	16	10	8
12	36	30	23	18	15	8	6
14	33	26	21	16	13	8	6
16	28	23	18	13	11	6	5
18	25	20	15	11	10	5	5
20	26	21	16	13	10	6	5
24	25	20	15	11	10	5	5

•NOTE: Maximum values stated are for extruded duct pipe only, and incorporate a 1.5:1 safety factor. Consideration should be given to system design, method of fabrication, and joining which may require additional system de-rating. Spears® PVC/CPVC Duct piping are not designed for distribution of compressed air or gases.



Duct System Installation

Joining Techniques

Spears® duct can be easily assembled in the field using standard thermoplastic pipe-joining techniques. The most common methods are solvent-cementing or thermal hot air welding, fusion welding and butt-welding can also be used. Retaining duct and fittings with suitable drilled holes and sheet metal screws may also be used, depending on application requirements.

Solvent Cementing

Typical duct fittings are fabricated from duct and with belled-end sockets that can be joined using solvent-cementing. This is the same basic process used for over 50 years in pressure pipe installation using the application of a primer and solvent cement to join system components. Properly made solvent cement joints are chemically fused together providing a leak-tight seal when cured. A minimum socket depth of 3" (all sizes) is necessary to provide sufficient surface-to-surface contact of the parts being joined. The use of extra-heavy-bodied solvent is recommended to handle the gap-filling required due to larger dimensional tolerances in duct piping. Use extra care when solvent cementing duct diameters 18" and larger to ensure tight fit of mating components. Do not use solvent cement for any type of end-to-end joining. See Installation section for industrial pressure pipe for guidelines on solvent cement welding.

Thermal Welding

Thermal welding requires the use of a hot-air welder and PVC or CPVC welding rod. Clean hot air from the welder preheats the duct material and welding rod while pressure is applied to the weld area as the rod is guided. This results in the surfaces of the parts being thermally fused together at the weld seam. Only welding rod produced from the same material being joined (same Cell Classification) should be used. Due to the significantly different thermal properties of the plastics, hot-air welding of CPVC is generally more difficult than PVC. Only personnel specifically trained in hot-air welding of PVC or CPVC should conduct all welding.

Hangers and Supports

As with all piping systems, proper support spacing is critical to minimize deflection and sagging. Additional support consideration must be given to concentrated loads, additional weight of accumulated solids, and independent support at fans, flexible connections, hoods, scrubbers, tanks, and other system components for potential stresses on the system.

Drains must be installed where accumulation of moisture is expected and at low points in the system (these locations should be specified on system specification drawings). Proper system inspection, cleaning and maintenance should be enforced to prevent the formation of additional weight loads. Refer to the following tables for maximum support spacing of horizontal air-filled duct with an allowable 1/8" deflection at various temperatures.

Hangers and supports shall be securely fastened to the building structure to avoid vibration, and should be installed in such a manner as to prevent conditions of stress on the system (properly aligned).

Seismic design and construction practices for hangers and supports shall be followed where applicable.

Hangers selected must have an adequate load-bearing surface free of rough or sharp edges to prevent damage to the duct during use. Use corrosive-resistant material for hangers and hanger hardware that is suitable for the system environment. Hangers must not restrict linear movement due to expansion and contraction. Avoid over tightening to prevent duct deformation and restriction of movement. Refer to the following illustration for examples of typical hangers.

Hanger Support Spacing

PVC Duct Maximum Hanger Support Spacing In Feet

Size (in.)	TEMPERATURE °F							
	73	80	90	100	110	120	130	140
6 x 1/8	9.5	9	9	8.5	8	7.5	7	6.5
6	10	10	9.5	9	8.5	8	7.5	6.5
7	10	10	9.5	9	8.5	8	7.5	7
8	10	10	10	10	9	9	8	7.5
9	10	10	10	10	10	9	8.5	8
10	10	10	10	10	10	10	9	8.5
11	10	10	10	10	10	10	9.5	9
12	12	12	12	12	10	10	10	9.5
14	12	12	12	12	11.5	11.5	11	10
16	12	12	12	12	12	12	11	10
18	12	12	12	12	12	12	11.5	11
20	12	12	12	12	12	12	12	11.5
24	12	12	12	12	12	12	12	12

CPVC Duct Maximum Hanger Support Spacing In Feet

Size (in.)	TEMPERATURE °F						
	73	100	120	140	160	180	200
6	10	10	10	10	10	8	8
8	10	10	10	10	10	8	8
10	10	10	10	10	10	10	10
12	10	10	10	10	10	10	10
14	12	12	12	12	10	10	10
16	12	12	12	12	12	10	10
18	12	12	12	12	12	12	12
20	12	12	12	12	12	12	12
24	12	12	12	12	12	12	12

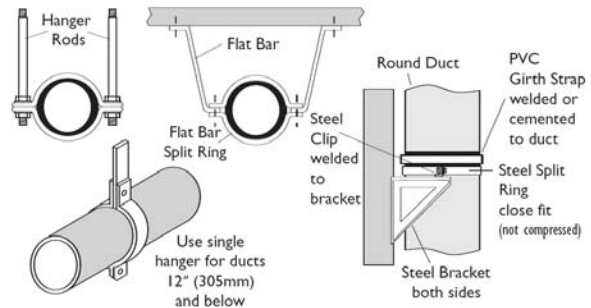



Thermal Expansion and Contraction

The coefficient of linear expansion (y) for Spears® duct can be found in the physical properties table (PVC = 2.9×10^{-5} in/in/°F; CPVC = 3.2×10^{-5} in/in/°F). As with all piping products, thermal expansion and contraction of the system must be considered and properly addressed during the design and installation of the system. The expansion or contraction rate of Spears® duct can be calculated as follows:

Thermal Expansion and Contraction for PVC Duct

$$\Delta L = 12 yL (\Delta T)$$

Where:

ΔL = Expansion or contraction of duct in inches

$y = 2.9 \times 10^{-5}$ in/in/°F (PVC duct material Coefficient of thermal expansion)

L = Length of duct run in feet

ΔT = Temperature change °F (T max. - T in.)

T max. = Maximum change in operating temperature (F)

T in. = Temperature at time of installation (F)

Thermal Expansion and Contraction for CPVC Duct

$$\Delta L = 12 yL (\Delta T)$$

Where:

ΔL = Expansion or contraction of duct in inches

$y = 3.2 \times 10^{-5}$ in/in/°F (CPVC duct material Coefficient of thermal expansion)

L = Length of duct run in feet

ΔT = Temperature change °F (T max. - T in.)

T max. = Maximum change in operating temperature (F)

T in. = Temperature at time of installation (F)

In-line expansion joints, either flexible sleeve type or O-ring piston type are the most common means of accommodating thermal expansion and contraction in duct systems. Using expansion loops and offsets where required can also be used, but require significantly more space.

Other Design Considerations

The duct system must not be exposed to conditions that will exceed product limitations regarding temperature, pressure, chemical compatibility and mechanical strength. Care must be taken to ensure that fume hood design, capture velocities, flow velocities, and flow volumes are adequate to properly convey the corrosive fumes being extracted while maintaining safety to personnel and protection of other equipment from corrosive attack. An optimum velocity for most systems is 1,500 feet per minute (FPM), which allows for future expansion of the system by increasing the fan size. With the exception of some heavy metals extraction, velocities exceeding 3,000 FPM are generally not recommended. This is especially true in system carrying solid particles where excessive static electricity can be generated. Minimum exhaust volume requirements in cubic feet per minute (CFM), must be calculated according to type and concentration of fumes being transported. Sufficient access for inspection and equipment maintenance must be provided. Size transition sections in mains and sub mains should be appropriately tapered for optimum flow conditions. A minimum taper of 5" in length for each 1" change in duct diameter is recommended. Branches should enter the main at the large end at angles no greater than 45° and not directly opposite each other. The designing engineer is responsible for ensuring that the system is in compliance with any applicable pollution control and building codes.