



Lab Specialty Products



ENGINEERING GUIDE

Contact Spears® for any Information not found.



Lab Ball Valves



Features - PVC, CPVC

This versatile quarter-turn shutoff valve is ideally suited for a variety of laboratory, system monitoring and OEM applications. Available in IPS sizes 1/4" - 3/8" with socket or threaded end connectors, plus 1/4" threaded Valve & Adapter Kit to provide multiple connection options.

- Chemical & Corrosion Resistant PVC or CPVC Construction
- Maintenance-Free Sealed Unit
- Individual Valve or Multi-functional Valve & Adapter Kit
- Schedule 80 Full-Bore Design
- High Impact Polypropylene Handle
- EPDM or FKM O-rings
- PTFE Floating Seat Design
- Sizes 1/4" - 3/8" Pressure Rated to 150 psi @ 73°F
- EPDM Valves NSF® Certified for Potable Water use
- Assembled with Silicone-Free, Water Soluble Lubricant

Sample Engineering Specification

All thermoplastic valves shall be sealed unit Lab type constructed from PVC Type I, ASTM D 1784 Cell Classification 12454 or CPVC Type IV, ASTM D 1784 Cell Classification 23447. All O-rings shall be EPDM or FKM. All valves shall have double stop Polypropylene handle. All 1/4" valves shall have optional field installable male thread and tubing end connector adapters. All EPDM valves shall be certified by NSF International for use in potable water service. All EPDM valves shall be pressure rated at 150 psi for water at 73°F, as manufactured by Spears® Manufacturing Company.

Quick-View Valve Selection Chart

Valve Size	O-ring Material	PVC Part Number ^{1,2}			Pressure Rating
		Socket	Threaded	Threaded with Kit	
1/4	EPDM	1522-002	1521-002	1529-002	150 psi Non-Shock Water @ 73°F
	FKM	1532-002	1531-002	1539-002	
3/8	EPDM	1522-003	1521-003	N/A	
	FKM	1532-003	1531-003	N/A	

1: For CPVC Valves, add the letter "C" to part number listed (e.g., 1521-002C)
 2: For valves with 1/4" I.D. tubing adapters, add the letter "A" to the part number listed (e.g., 1529-002A)



LAB BALL VALVE WITH ADAPTER KIT

Valve & Adapter Kit

Kit allows multiple connection options. Adapters use O-ring seals for easy connection to threaded valve. Complete Kit includes:

- 1 - Threaded 1/4" Valve
- 2 - O-ring Sealed 1/4" MPT x Mipt Adapters
- 2 - EPDM or FKM O-rings (AS568-013 size)
- 1 - End Connector Wrench
- 2 - O-ring Sealed 1/4" MPT x 3/8" I.D. Tubing Barb Adapters - OR -
- 2 - O-ring Sealed 1/4" MPT x 1/4" I.D. Tubing Barb Adapters (Must Add "A" to Valve/Kit Part No.)

Lab Ball Valve Adapter Kit Only

Valve Size	O-ring Material	Part Number	
		PVC	CPVC
1/4	EPDM	LVKE-002	LVKE-002C
	FKM	LVKV-002	LVKV-002C

- Kit Includes:**
- 2 - O-rings
 - 1 - End Connector Wrench
 - 2 - 1/4" MPT x Mipt Adapters
 - 2 - 1/4" MPT x 3/8" I.D. Tubing Barb Adapters

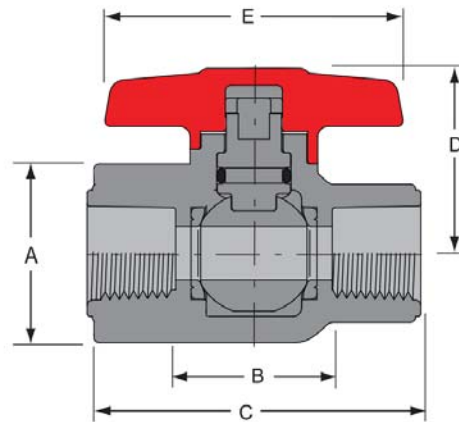

Basic Valve

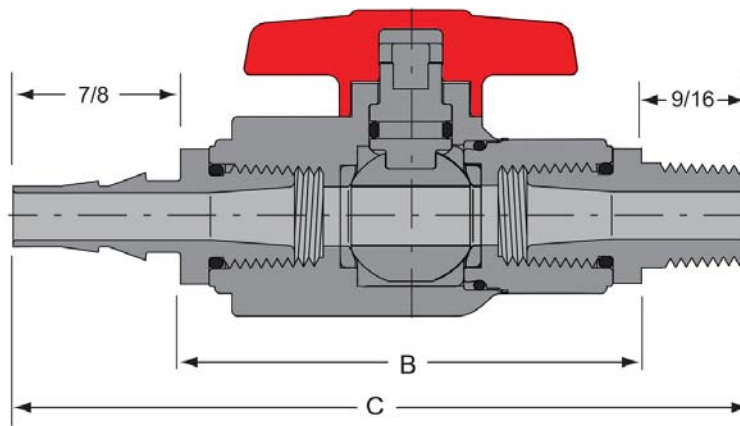

Valve with Adapter Kit

Dimensions, Weights & C_v Values

Nominal Size	Dimension Reference (inches, ± 1/16)					Approx. Wt. (Lbs.)		C _v ² Values
	A	B ¹	C	D	E	PVC	CPVC	
1/4	1-1/16	15/16	2-1/8	1-1/16	1-3/4	.10	.11	10
1/4 w/Kit	1-1/16	2-7/16	3-7/8	1-1/16	1-3/4	.14	.15	6
3/8	1-5/16	1	2-3/16	1-1/4	2	.12	.13	24

1: Valve Lay Length

2: Gallons per minute at 1 psi pressure drop. Values calculated from valve laying length, based on derivative of Hazen-Williams equation with roughness factor of C=150.

Temperature Pressure Rating

System Operating Temperature °F (°C)		73 (23)	100 (38)	110 (43)	120 (49)	130 (54)	140 (60)	150 (66)	160 (71)	170 (77)	180 (82)	190 (88)
Valve Pressure Rating psi (MPa)	PVC	150 (1.03)	124 (.85)	100 (.69)	75 (.52)	-0 (-0-)	-0 (-0-)	-0 (-0-)	-0 (-0-)	-0 (-0-)	-0 (-0-)	-0 (-0-)
	CPVC	150 (1.03)	140 (.97)	130 (.90)	120 (.83)	110 (.76)	100 (.69)	90 (.62)	80 (.55)	70 (.48)	60 (.41)	-0 (-0-)



Needle Valves



Features - PVC, CPVC & PP

Needle Valves provide proportional opening to needle travel for more accurate metering applications and other fine adjustment flow control applications. Special design PTFE seal eliminates elastomer type seals or O-rings that can contribute to chemical compatibility problems. PVC, CPVC and Polypropylene valves are available with 1/4", 3/8" and 1/2" NPT female threaded ends in either standard Globe Pattern or special Angle Pattern configuration that eliminates need for additional elbow in various system setups.

- Chemical & Corrosion Resistant PVC, CPVC or PP Construction
- Precision Metering Chamber
- Globe & Angle Body Configurations
- Removable Bonnet For Easy Disassembly & Cleaning
- Solid PTFE Stem Seal - No Elastomer Seal or Lubricants Used
- Built-in Panel or Bracket Mounting Nut
- Easy-Grip Polypropylene Handle
- PVC & CPVC Pressure Rated to 235 psi @ 73°F Polypropylene Pressure Rated to 150 psi @ 73°F

Sample Engineering Specification

All thermoplastic Needle Valves shall be constructed from PVC, ASTM D 1784 Cell Classification 12454, CPVC, ASTM D 1784 Cell Classification 23447, or Polypropylene, ASTM D 4101. All valves shall be globe pattern or angle pattern body configuration with 1/4", 3/8" or 1/2" female NPT end connections. All valves shall have removable bonnet cap with replaceable PTFE seal. No elastomer seals shall be used. All valves shall have built-in panel mounting nut and high impact polypropylene handles. All PVC and CPVC valves shall be pressure rated to 235 psi and all Polypropylene valves to 150 psi for water @ 73°F, as manufactured by Spears® Manufacturing Company.

C_v Values

Size	Globe Pattern	Angle Pattern
1/4" - 3/8"	.310	.426
1/2"	.62	.78

Gallons per minute at 1 psi pressure drop.

Quick-View Needle Valve Selection Chart

Valve Size	PVC Part Numbers ^{1,2}						Pressure Rating
	Globe Pattern			Angle Pattern			
	Socket	SR Threaded	Threaded	Socket	SR Threaded	Threaded	
1/4"	5592-002	N/A	5591-002	5692-002	N/A	5691-002	PVC & CPVC 235 psi, PP 150 psi Non-Shock Water @ 73°F
3/8"	5592-003	5591-003SR	5591-003	5692-003	N/A	5691-003	
1/2"	5592-005	5591-005SR	5591-005	5692-005	5691-005SR	5691-005	

1: For CPVC Valve, add the letter "C" to the part number (e.g. 5591-002C)

2: For threaded Polypropylene Valve, add the letter "P" to the part number (e.g. 5591-002P, 5591-005PSR)

Temperature Pressure Rating

System Operating Temperature °F (°C)		100 (38)	110 (43)	120 (49)	130 (54)	140 (60)	150 (66)	160 (71)	170 (77)	180 (82)	190 (88)	200 (93)	210 (99)	
Valve Pressure Rating psi (MPa)	1/4"-1/2"	PVC	235 (1.62)	211 (1.45)	150 (1.03)	75 (.52)	50 (.34)	-0- (-0-)	-0- (-0-)	-0- (-0-)	-0- (-0-)	-0- (-0-)	-0- (-0-)	
		CPVC	235 (1.62)	219 (1.51)	170 (1.17)	145 (1.00)	130 (.90)	110 (.76)	90 (.62)	80 (.55)	70 (.48)	60 (.41)	50 (.34)	-0- (-0-)
		PP	150	105	90	80	65	50	45	30	20	-0-	-0-	-0-



Panel Mounting Instructions

Spears® Needle Valves may be easily mounted to panel or bracket ranging from 3/16" to 1/2" in thickness using the accompanying template. Prepare mounting hole to panel opening dimensions. Slots may be cut in various positions to allow more versatile orientation. Open valve partially. Remove Bonnet Cap with needle assembly (do not fully disassemble) and Panel Nut from valve body. Insert valve body through mounting hole and seat lugs. Reinstall Panel Nut and tighten snug. Carefully reinstall Bonnet Cap and needle assembly, tighten snug. **Caution:** Failure to partially open the valve or back the needle off prior to re-assembly may damage needle when tightening Bonnet Cap.

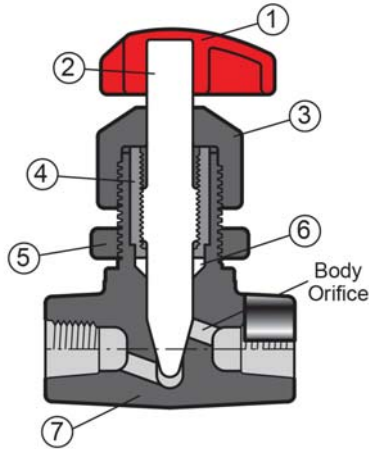

Replacement Parts

No.	Component	Qty.	Material
1	Handle	1	PP
2	Needle Stem	1	PVC/CPVC/PP
3	Bonnet Cap	1	PVC/CPVC/PP
4	Stem Nut	1	GFPP
5	Panel Nut	1	PVC/CPVC/PP
6	Seal	1	PTFE
7	Body	1	PVC/CPVC/PP

Panel Opening

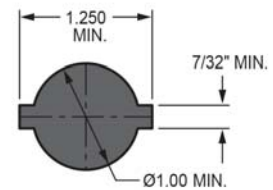

Body Orifice Dimensions

Valve Size	Body Orifice Ø
1/4	3/16"
3/8	3/16"
1/2	1/4"

Globe Pattern

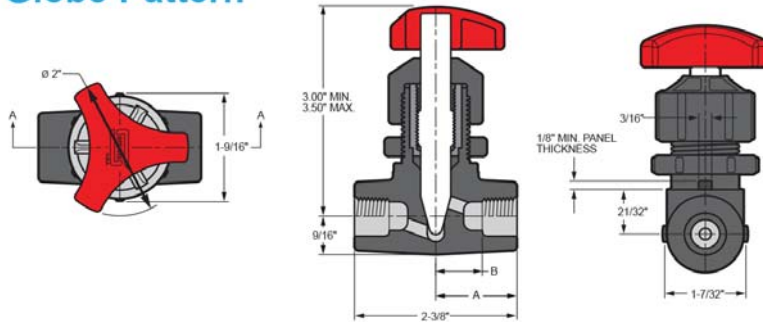

Dimensions

Valve Size	End Connection	A	B
1/4	Threaded	1-3/16	21/32
	Socket		9/16
3/8	Threaded		9/16
	Socket		7/16
1/2	Threaded	1-3/8	21/32
	Socket		1/2

Threaded Valve Dimensions apply to both Standard and SR Threads.

Angle Pattern

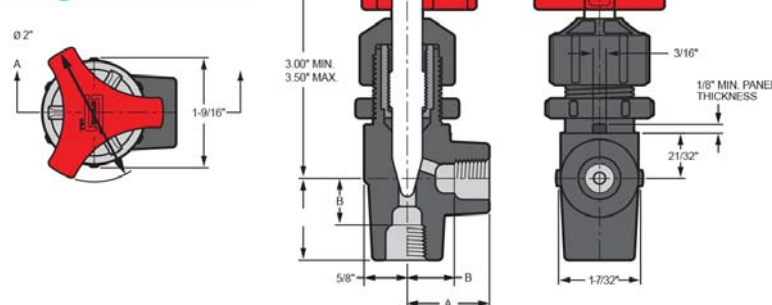

Needle Valve Adapter Kit

Valve Size	O-ring Material	Part Number	
		PVC	CPVC
1/4	EPDM	LVKE-002	LVKE-002C
	FKM	LVKV-002	LVKV-002C

Kit Includes:

- 2 - O-rings
- 1 - End Connector Wrench
- 2 - 1/4" MPT x Mipt Adapters
- 2 - 1/4" MPT x 3/8" I.D. Tubing Barb Adapters



Gauge Guards



Optional gauge shown, not included with basic unit

Quick View Gauge Guard Selection

Inlet Size (in.)	PVC Part Numbers ^{1,2,3}		
	Diaphragm		
	PTFE	EPDM	FKM
1/4	G0004-002	G0002-002	G0003-002
1/2	G0004-005	G0002-005	G0003-005

- 1: Gauge Guard only. Contact Spears® for pre-filled Gauge & Gauge Guard combination units.
- 2: For CPVC, add the letter "C" to the part number (e.g., G0004-002C)
- 3: For PP, add the letter "P" to the part number (e.g., G0004-002P)

General Installation Information

The Gauge Guard and gauge must be completely filled with a suitable liquid, such as glycerin or distilled water, on the gauge side of the diaphragm in order to accurately transmit system pressure or vacuum. Follow packaged instructions for proper filling and installation. Factory installed Gauge & Gauge Guard units are pre-filled. (Contact Spears® Technical Service for additional information). While PTFE diaphragms generally have a broader range of chemical resistance, FKM or EPDM elastomer diaphragms are more sensitive and should be used in low pressure (i.e., 0-15 psi) and vacuum applications.

Features - PVC, CPVC & PP

Gauge Guards isolate process pressure or vacuum gauges from corrosive or other potentially damaging process media by use of a thin PTFE (standard) FKM, or EPDM diaphragm. This flexible membrane accurately transmits system pressure to gauge connection chamber when properly assembled with gauge and liquid filled. Available in PVC, CPVC or Polypropylene construction with 1/2" x 1/4" or 1/4" x 1/4" inlet x outlet NPT connections.

- PTFE Diaphragm (Standard), FKM or EPDM Available
- Type 316 Stainless Steel Fasteners
- 1/4" NPT Gauge Port with O-ring Seal - No Thread Sealant Required
- 1/4" or 1/2" NPT Pressure Inlet Featuring Spears® Patented Special Reinforced (SR) Female Plastic Thread - Suitable for either Plastic or Metal Male NPT Thread Connection
- Pressure Rated to 235 psi @ 73°F, 16 Bar @ 22°C and Full Vacuum Service
- Mount in Any Position

Note: Elevated service temperatures require system pressure de-rating.

Optional Pre-filled, Factory Installed Gauge & Gauge Guard

Gauge Type	Available Range	Dial	Connection	Housing
Pressure	0-15 psi 0-30 psi 0-60 psi 0-100 psi 0-160 psi 0-200 psi 0-300 psi	Black marking on white face, black dial	1/4 NPT Brass, Bottom Mount	Steel cased, Epoxy enamel finish
Vacuum	0-30 in-Hg			

Dimensions

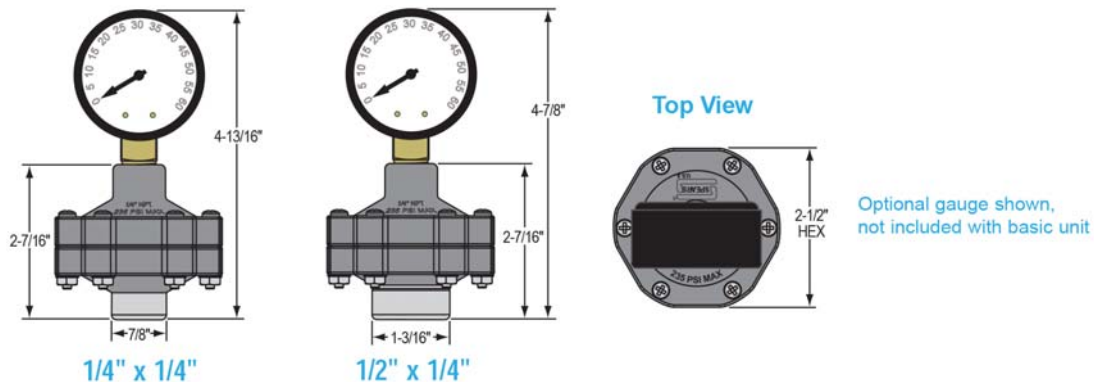

Lab Fixtures

100% Corrosion Resistance - No Metal Parts

Spears® Lab Fixtures have no metal parts; this provides full resistance to internal or environmental corrosion. These fixtures are compatible with all laboratory service lines. Lab Fixtures are produced from PVC (gray) and CPVC (for hot water), or special Low-Extractable PVC for high purity applications, and are available in a variety of types and configurations.

- **Deck Mount** - base configuration for horizontal surface mounting.
- **Panel Mount** - base configuration for vertical surface mounting.
- **Standard Gooseneck Units** - select all-plastic needle valve unit (no elastomer seals) for metered flow or ball valve unit (choice of EPDM or FKM seals) for direct flow. Unit includes valve, gooseneck with serrated tip, and base with nut for mounting. Select Deck or Panel Mount style.
- **Standard Turret Units** - direct flow ball valve (choice of EPDM or FKM seals) with serrated tip and base with connecting nipple and nut for mounting. Select Deck or Panel Mount style.
- **Remote Valve Units (No Valve)** - same as standard units less valve for use with remotely located valve.
- **Recirculating Units** - Special design provides continuous water motion without dead-leg areas of contamination and potential bacteria build-up. Internal supply tube fully circulates water through the entire fixture when connected to circulating water supply. Unit features gooseneck with terminally mounted all-plastic needle valve and serrated tip (no elastomer seals) for metered flow. Base is Deck Mount only with inlet and outlet connecting nipples with mounting nuts.

NPT - American National Standard Tapered Pipe Thread • NPSM - American National Standard Straight Thread For Free Fitting Mechanical Joints

Standard Gooseneck Units - Deck Mount Lab Fixture -
 Base with Valve, Gooseneck & Serrated Tip with Needle Valve-Metered Flow

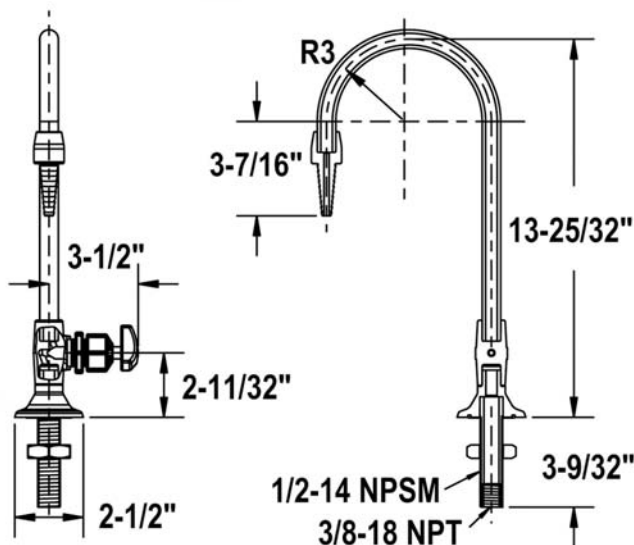

Standard Gooseneck Units - Deck Mount Lab Fixture -
 with Ball Valve Direct Flow

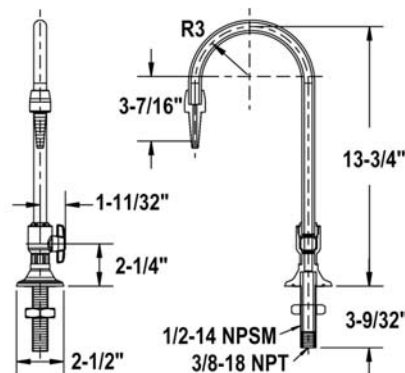

Standard Gooseneck Units - Panel Mount Lab Fixture -
 Base with Valve, Gooseneck & Serrated Tip with Needle Valve-Metered Flow

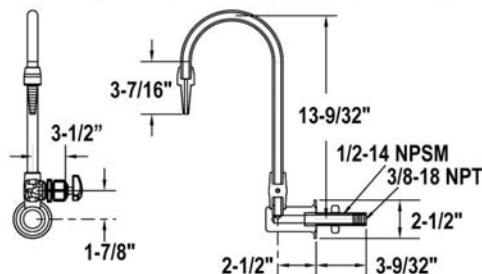



Standard Gooseneck Units - Panel Mount Lab Fixture - with Ball Valve-Direct Flow

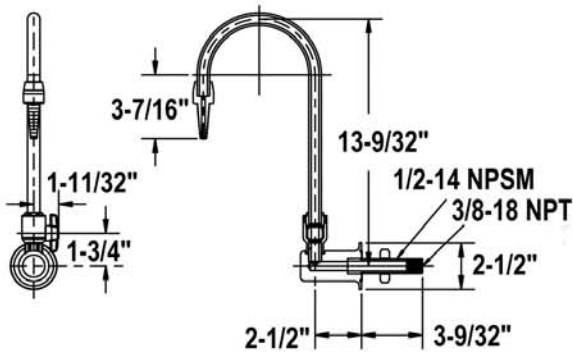

Standard Turret Units - Panel Mount Turret Lab Fixtures Base - with Valve & Serrated Tip with Ball Valve-Direct Flow

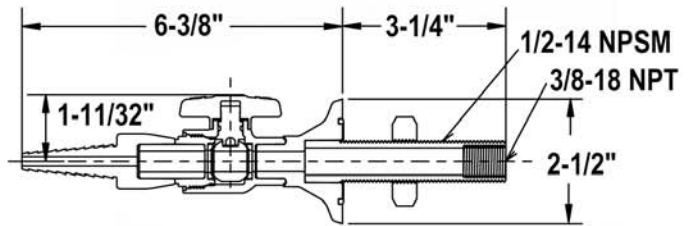

Standard Turret Units - Deck Mount Turret Lab Fixtures Base - with Valve & Serrated Tip with Ball Valve-Direct Flow

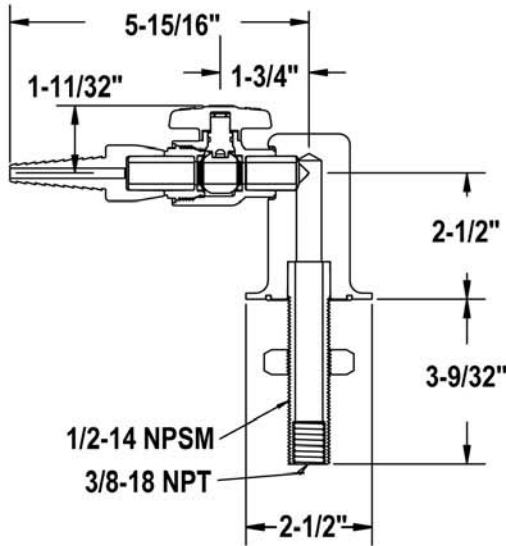

Remote Valve Units (No Valve) - Deck Mount Gooseneck - Base with Gooseneck & Serrated Tip

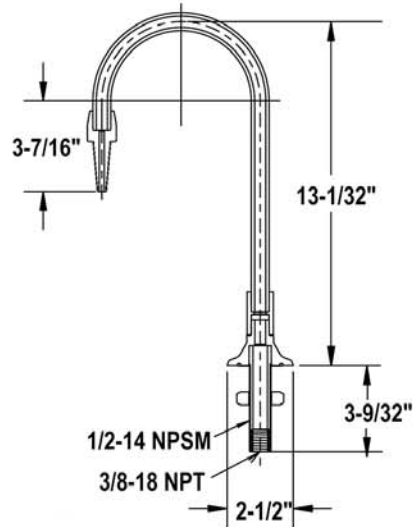

Remote Valve Units (No Valve) - Panel Mount Gooseneck - Base with Gooseneck & Serrated Tip

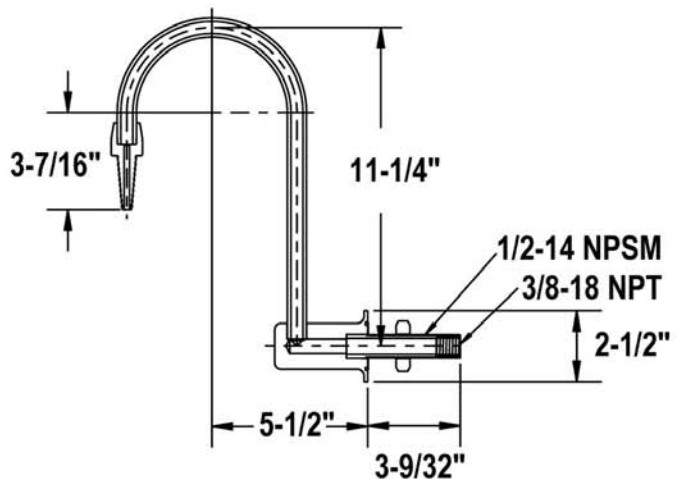

Remote Valve Units (No Valve) - Deck Mount Turret - Base with Serrated Tip

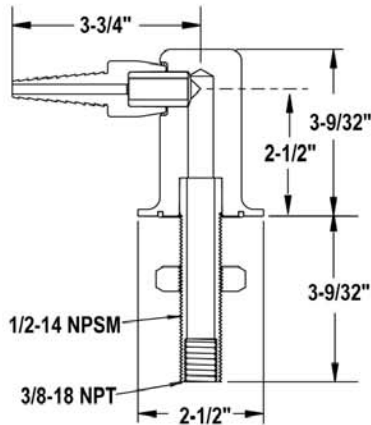

Accessory / Replacement - Gooseneck (3/8")

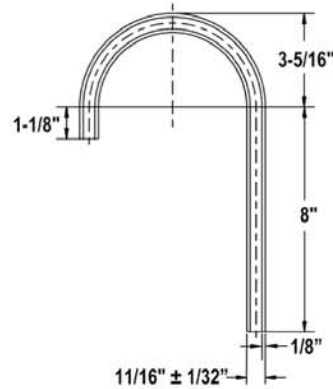

Recirculating Units - Recirculating Deck Mount Lab Fixture - Base with Gooseneck, Valve & Serrated Tip with Needle Valve

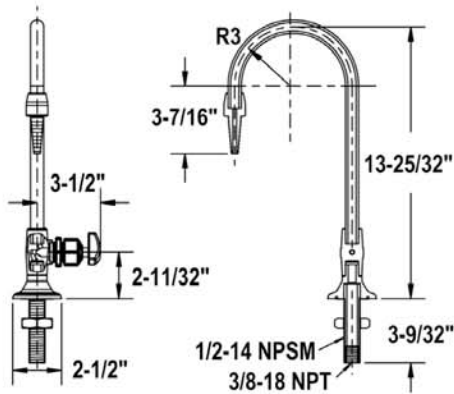

Accessory / Replacement - Base

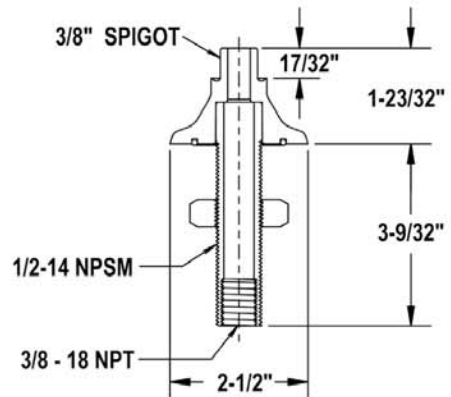

Accessory / Replacement - Straight Serrated Tip

