

Fabricated Fittings Technical
PVC Schedule 40 & 80 Low Pressure Fabricated Fittings

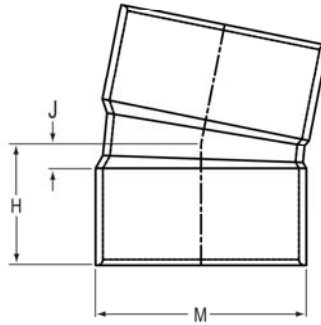

11-1/4° Elbow SCH 40

Socket x Socket



Part Number	Size	H	J	M	Approx. Wt. (Lbs.)
3711-040	4	3	3/4	5	1.39
3711-060	6	4- 1/4	1	7- 3/16	2.95
3711-080	8	5-5/16	1-1/16	9-1/4	4.84
3711-100	10	6-11/16	1-7/16	11-1/2	9.41
3711-120	12	7-13/16	1-9/16	13-9/16	14.09
3711-140	14	9	2	14-7/8	20.77
3711-160	16	10-3/8	2-3/8	16-3/4	28.88
3711-180	18	11-11/16	2-11/16	19-1/8	42.88
3711-200	20	13-1/16	3-1/16	21-3/16	55.12
3711-240	24	15-3/4	3-3/4	25-3/8	95.34

11-1/4° Elbow SCH 80

Socket x Socket

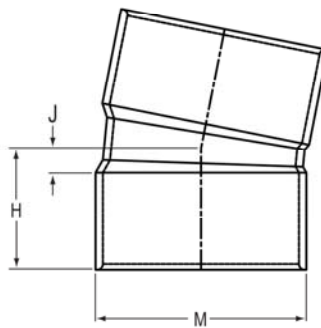

Part Number	Size	H	J	M	Approx. Wt. (Lbs.)
3911-040	4	3	3/4	5-3/16	1.65
3911-060	6	4-1/4	1	7-1/2	4.67
3911-080	8	5-3/8	1-1/8	9-5/8	6.56
3911-100	10	6-11/16	1-7/16	11-15/16	15.43
3911-120	12	7-13/16	1-9/16	14-1/8	24.62
3911-140	14	9	2	15-1/2	33.00
3911-160	16	10- 3/8	2- 3/8	17-11/16	48.75
3911-180	18	11-3/4	2-3/4	19-7/8	72.67
3911-200	20	13-1/8	3-1/8	22-1/16	99.19



Fabricated Fittings Technical
PVC Schedule 40 & 80 Low Pressure Fabricated Fittings

11-1/4° Elbow SCH 80

(Continued)

Socket x Socket

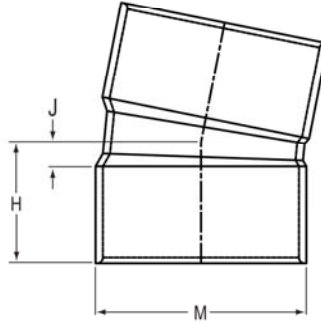

Part Number	Size	H	J	M	Approx. Wt. (Lbs.)
3911-240	24	15-13/16	3-13/16	26-7/16	169.84

15° Elbow SCH 40

Socket x Socket

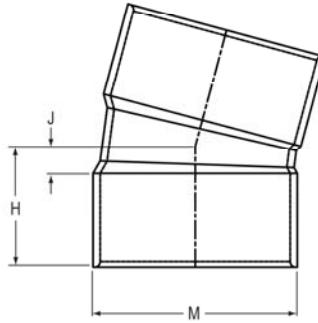

Part Number	Size	H	J	M	Approx. Wt. (Lbs.)
3718-040	4	3-1/16	13/16	5	1.36
3718-060	6	4-3/8	1-1/8	7-3/16	2.66
3718-080	8	5-1/2	1-1/4	9-1/4	5.95
3718-100	10	6-7/8	1-5/8	11-1/2	9.41
3718-120	12	8	1-3/4	13-9/16	14.09
3718-140	14	9-1/4	2-1/4	14-7/8	20.77
3718-160	16	10-5/8	2-5/8	17	30.20
3718-180	18	12	3	19-1/8	44.60
3718-200	20	13-7/16	3-7/16	21-3/16	57.09
3718-240	24	16-3/16	4-3/16	25-3/8	98.14

Fabricated Fittings Technical
PVC Schedule 40 & 80 Low Pressure Fabricated Fittings



15° Elbow SCH 80

Socket x Socket

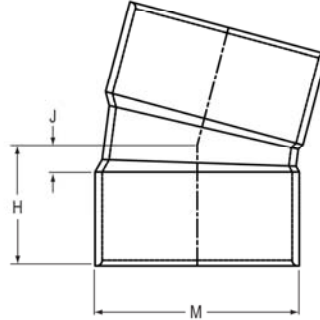

Part Number	Size	H	J	M	Approx. Wt. (Lbs.)
3918-040	4	3-1/8	7/8	5-3/16	1.89
3918-060	6	4-3/8	1-1/8	7- 1/2	4.67
3918-080	8	5-1/2	1-1/4	9-5/8	9.23
3918-100	10	6-15/16	1-11/16	11-15/16	15.43
3918-120	12	8-1/16	1-13/16	14-1/8	26.07
3918-140	14	9-5/16	2-5/16	15-1/2	32.99
3918-160	16	10-11/16	2-11/16	17-11/16	48.75
3918-180	18	12-1/16	3-1/16	19-7/8	72.67
3918-200	20	13-1/2	3-1/2	22-1/16	99.19
3918-240	24	16-1/4	4-1/4	26-7/16	169.84

22-1/2° Elbow SCH 40

Socket xSocket

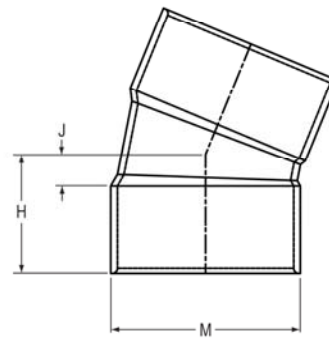

Part Number	Size	H	J	M	Approx. Wt. (Lbs.)
3716-040	4	3-1/4	1	5	1.36
3716-060	6	4- 5/8	1- 3/8	7- 3/16	3.24
3716-080	8	5-13/16	1-9/16	9- 1/4	5.72
3716-100	10	7-5/16	2-1/16	11-1/2	10.04
3716-120	12	8-1/2	2-1/4	13-9/16	14.91
3716-140	14	9-3/4	2-3/4	14-7/8	20.77
3716-160	16	11-1/4	3-1/4	17	30.96
3716-180	18	12-11/16	3-11/16	19-1/8	46.31
3716-200	20	14-1/8	4-1/8	21- 3/16	59.06



Fabricated Fittings Technical
PVC Schedule 40 & 80 Low Pressure Fabricated Fittings

22-1/2° Elbow SCH 40

(Continued)

Socket x Socket

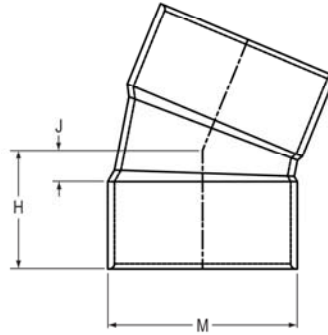

Part Number	Size	H	J	M	Approx. Wt. (Lbs.)
3716-240	24	17-1/16	5-1/16	25-3/8	100.95

22-1/2° Elbow SCH 80

Socket x Socket

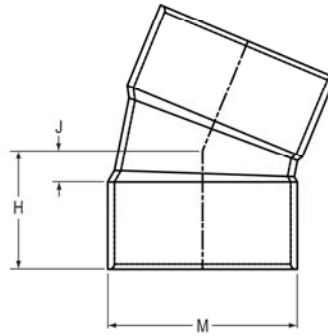

Part Number	Size	H	J	M	Approx. Wt. (Lbs.)
3916-040	4	3-1/4	1	5-3/16	1.89
3916-060	6	4-5/8	1-3/8	7- 1/2	5.14
3916-080	8	5-7/8	1-5/8	9- 5/8	7.06
3916-100	10	7-5/16	2-1/6	11-15/16	20.59
3916-120	12	8-9/16	2-5/16	14- 1/8	27.52
3916-140	14	9-13/16	2-13/16	15-1/2	34.64
3916-160	16	11-5/16	3-5/16	17-11/16	52.97
3916-180	18	12-3/4	3-3/4	19-7/8	74.44
3916-200	20	14-1/4	4-1/4	22-1/16	106.03
3916-240	24	17-3/16	5-3/16	26-7/16	189.95

Fabricated Fittings Technical
PVC Schedule 40 & 80 Low Pressure Fabricated Fittings



22-1/2° Street EII SCH 40

Spigot x Socket

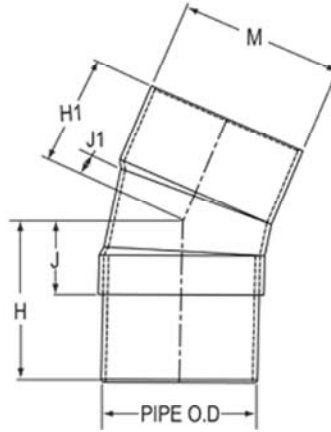

Part Number	Size	H	H1	J	J1	M1	Approx. Wt. (Lbs.)
3742-060	6	6-3/4	3-1/8	2-3/4	1/8	7-3/16	2.59
3742-080	8	8-11/16	3-1/2	3-11/16	3/4	9-1/4	6.94
3742-100	10	10-5/8	4-7/16	4-5/8	13/16	11-1/2	10.67
3742-120	12	12-1/4	5-3/16	5-1/4	1-1/16	13-9/16	15.74
3742-140	14	14-9/16	5-9/16	6-9/16	1-7/16	14-7/8	21.69
3742-160	16	16-7/8	6-1/16	7-7/8	1-15/16	17	32.82
3742-180	18	18-3/16	12-11/16	8-3/16	3-11/16	19-1/8	63.47
3742-200	20	20-1/8	14-1/8	9-1/8	4-1/8	21-3/16	80.72
3742-240	24	24-1/16	17-1/16	11-1/16	5-1/16	25-3/8	137.41

22-1/2° Street EII SCH 80

Spigot x Socket

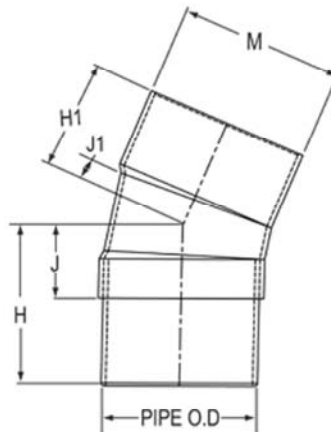

Part Number	Size	H	H1	J	J1	M1	Approx. Wt. (Lbs.)
3942-060	6	6-5/8	3-5/16	2-5/8	1/16	7-1/2	5.14
3942-080	8	8-11/16	3-9/16	3-11/16	11/16	9-5/8	9.94
3942-100	10	11-5/8	4-5/8	4-5/8	5/8	11-15/16	17.48
3942-120	12	11-15/16	5-3/4	5-15/16	1/2	14-1/8	27.52
3942-140	14	14-1/16	6-5/16	6-1/16	11/16	15-1/2	36.29
3942-160	16	17-1/4	5-15/16	8-1/4	2-1/16	17-11/16	46.25
3942-180	18	18-1/4	12-3/4	8-1/4	3-3/4	19-7/8	106.22
3942-200	20	20-1/4	14-1/4	9-1/4	4-1/4	22-1/16	143.66
3942-240	24	24-3/16	17-3/16	11-3/16	5-3/16	26-7/16	247.49



Fabricated Fittings Technical
PVC Schedule 40 & 80 Low Pressure Fabricated Fittings

30° Elbow SCH 40

Socket x Socket

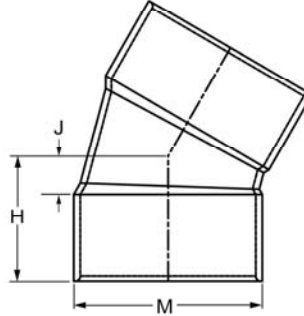

Part Number	Size	H	J	M	Approx. Wt. (Lbs.)
3715-040	4	3-7/16	1-3/16	5	1.53
3715-060	6	4-7/8	1-5/8	7-3/16	3.20
3715-080	8	6-1/8	1-7/8	9- 1/4	5.39
3715-100	10	7-11/16	2-7/16	11-1/2	10.66
3715-120	12	9	2- 3/4	13- 9/16	16.57
3715-140	14	10-5/16	3-5/16	14- 7/8	23.88
3715-160	16	11-13/16	3-13/16	17	34.14
3715-180	18	13-3/8	4-3/8	19-1/8	49.74
3715-200	20	14-15/16	4-15/16	21-3/16	63.00
3715-240	24	18	6	25-3/8	109.36

30° Elbow SCH 80

Socket x Socket

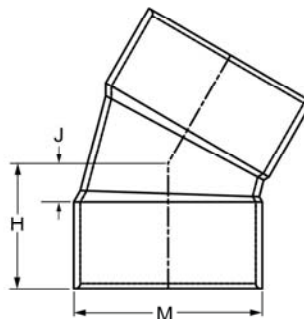

Part Number	Size	H	J	M	Approx. Wt. (Lbs.)
3915-040	4	3-7/16	1-3/16	5- 3/16	2.13
3915-060	6	4-7/8	1-5/8	7-1/2	5.61
3915-080	8	6-3/16	1-15/16	9- 5/8	10.65
3915-100	10	7-3/4	2-1/2	11-15/16	18.51
3915-120	12	9-1/16	2-13/16	14-1/8	28.97
3915-140	14	10-7/16	3-7/16	15-1/2	37.94
3915-160	16	11-15/16	3-15/16	17-11/16	61.48
3915-180	18	13-1/2	4-1/2	19-7/8	83.85
3915-200	20	15	5	22-1/16	112.87

Fabricated Fittings Technical
PVC Schedule 40 & 80 Low Pressure Fabricated Fittings



30° Elbow SCH 80

(Continued)

Socket x Socket

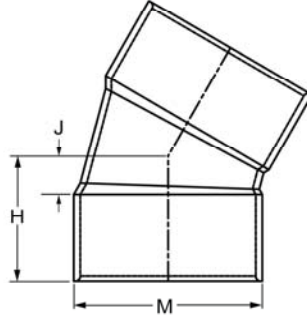

Part Number	Size	H	J	M	Approx. Wt. (Lbs.)
3915-240	24	18-1/8	6-1/8	26-7/16	191.00

45° Elbow SCH 40

Socket x Socket

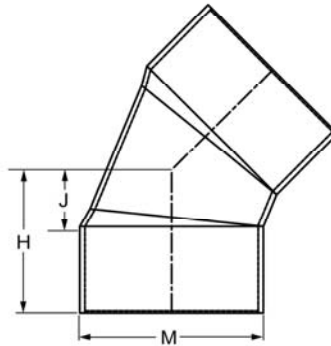

Part Number	Size	H	J	M	Approx. Wt. (Lbs.)
3717-060	6	5-7/16	2-3/16	7- 3/16	3.47
3717-080	8	6-7/8	2-5/8	9-1/4	7.44
3717-100	10	8-9/16	3-5/16	11- 1/2	10.33
3717-120	12	10	3- 3/4	13- 9/16	15.96
3717-140	14	11-7/16	4-7/16	14-7/8	25.96
3717-160	16	13-1/8	5-1/8	17	34.85
3717-180	18	14-7/8	5-7/8	19-1/8	54.89
3717-200	20	16-9/16	6-9/16	21- 3/16	68.90
3717-240	24	19-15/16	7-15/16	25-3/8	117.78



Fabricated Fittings Technical
PVC Schedule 40 & 80 Low Pressure Fabricated Fittings

45° Elbow SCH 80

Socket x Socket

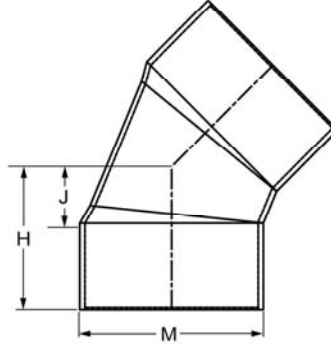

Part Number	Size	H	J	M	Approx. Wt. (Lbs.)
3917-060	6	5- 1/2	2- 1/4	7- 1/2	4.95
3917-080	8	6-15/16	2-11/16	9- 5/8	11.42
3917-100	10	8-11/16	3-7/16	11-15/16	17.37
3917-120	12	10-1/8	3-7/8	14- 1/8	31.86
3917-140	14	11-9/16	4-9/16	15-1/2	41.24
3917-160	16	13-5/16	5-5/16	17-11/16	61.48
3917-180	18	15	6	19-7/8	87.73
3917-200	20	16-3/4	6-3/4	22- 1/16	112.97
3917-240	24	20-3/16	8-3/16	26- 7/16	208.66

60° Elbow SCH 40

Socket x Socket

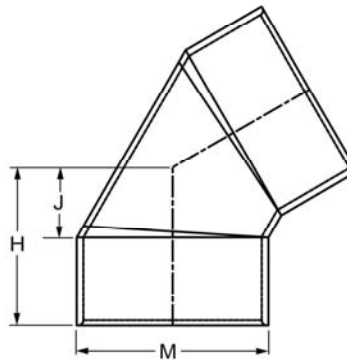

Part Number	Size	H	J	M	Approx. Wt. (Lbs.)
3724-060	6	6-1/16	2-13/16	7-3/16	3.54
3724-080	8	7-5/8	3-3/8	9-1/4	6.60
3724-100	10	9-9/16	4-5/16	11-1/2	11.60
3724-120	12	11-3/16	4-15/16	13-9/16	17.46
3724-140	14	12-3/4	5-3/4	14-7/8	28.03
3724-160	16	16-5/8	6-5/8	17	36.38
3724-180	18	16-9/16	7-9/16	19-1/8	60.04
3724-200	20	23-11/16	13-11/16	22-1/16	106.31
3724-240	24	28-3/8	16-3/8	25-3/8	122.08

Fabricated Fittings Technical
PVC Schedule 40 & 80 Low Pressure Fabricated Fittings



60° Elbow SCH 80

Socket x Socket

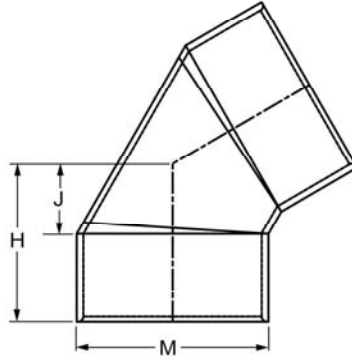

Part Number	Size	H	J	M	Approx. Wt. (Lbs.)
3924-060	6	6-1/8	2-7/8	7-1/2	5.85
3924-080	8	7-3/4	3-1/2	9- 5/8	18.81
3924-100	10	9-11/16	4-7/16	11-15/16	21.60
3924-120	12	11-5/16	5-1/16	14-1/8	34.76
3924-140	14	12-15/16	5-15/16	15-1/2	41.18
3924-160	16	14-13/16	6-13/16	17-11/16	65.72
3924-180	18	16-3/4	7-3/4	19-7/8	97.83
3924-200	20	23-11/16	13-11/16	22-1/16	232.59
3924-240	24	28-11/16	16-11/16	26-7/16	325.13

90° Street Ell SCH 40

Spigot x Socket

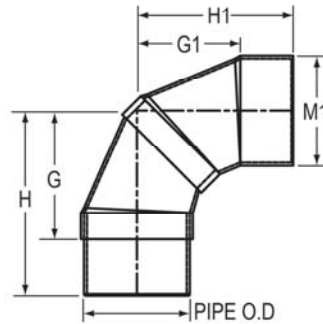

Part Number	Size	G	G1	H	H1	M1	Approx. Wt. (Lbs.)
3709-040	4	7-7/16	5-15/16	10-7/16	8-3/16	5	4.08
3709-060	6	6-1/8	6-1/8	9-3/8	9-3/8	7-3/16	5.60
3709-080	8	7-1/2	7-1/2	11-3/4	11-3/4	9-1/4	10.02
3709-100	10	9-9/16	9-9/16	14-13/16	14-13/16	11-1/2	20.09
3709-120	12	10-15/16	10-15/16	17-3/16	17-3/16	13-9/16	30.66
3709-140	14	12-15/16	12-15/16	19-15/16	19-15/16	14-7/8	44.65
3709-160	16	19-1/4	15-1/4	28-1/4	23-1/4	17	74.84
3709-180	18	21-13/16	17-5/16	31-13/16	26-5/16	19-1/8	115.96
3709-200	20	24-3/8	19-3/8	35-3/8	29-3/8	21-3/16	139.78
3709-240	24	29-7/16	23-7/16	42-7/16	35-7/16	25-3/8	238.36



Fabricated Fittings Technical
PVC Schedule 40 & 80 Low Pressure Fabricated Fittings

90° Street Ell SCH 80

Spigot x Socket

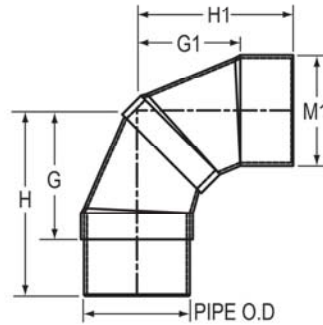

Part Number	Size	G	G1	H	H1	M1	Approx. Wt. (Lbs.)
3909-040	4	4-7/8	4-5/8	7-3/8	6-7/8	5-1/4	4.29
3909-060	6	6-1/8	6-1/8	9-3/8	9-3/8	7-1/2	12.11
3909-080	8	7-5/8	7-7/16	11-7/8	11-11/16	9-5/8	18.17
3909-100	10	9-9/16	9-5/8	14-13/16	14-7/8	11-15/16	33.94
3909-120	12	11-1/8	10-7/8	17-3/8	17-1/8	14-1/8	55.04
3909-140	14	13-1/2	13-1/2	20-1/2	20-1/2	15-1/2	70.94
3909-160	16	19-9/16	15-9/16	28-9/16	23-9/16	17-11/16	122.96
3909-180	18	22-3/16	17-11/16	32-3/16	26-11/16	19-7/8	181.69
3909-200	20	24-13/16	19-13/16	35-13/16	29-13/16	22-1/16	233.25
3909-240	24	30	24	43	36	26-7/16	422.19

45° Street Ell SCH 40

Spigot x Socket

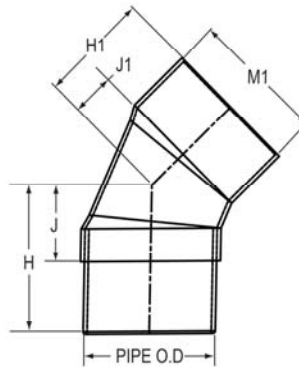

Part Number	Size	H	H1	J	J1	M1	Approx. Wt. (Lbs.)
3727-040	4	6-1/16	3-13/16	3-1/16	1-9/16	5	2.03
3727-060	6	5-5/16	5-5/16	2-1/16	2-1/16	7-3/16	3.14
3727-080	8	6-3/4	6-3/4	2-1/2	2-1/2	9-1/4	5.72
3727-100	10	8-1/2	8-1/2	3-1/4	3-1/4	11-1/2	11.92
3727-120	12	10	10	3-3/4	3-3/4	13-9/16	16.29
3727-140	14	11-7/16	11-7/16	4-7/16	4-7/16	14-7/8	22.00
3727-160	16	18-1/8	13-1/8	9-1/8	5-1/8	17	44.00
3727-180	18	20-3/8	14-7/8	10-3/8	5-7/8	19-1/8	66.00
3727-200	20	22-9/16	16-9/16	11-9/16	6-9/16	21-3/16	84.00

Fabricated Fittings Technical
PVC Schedule 40 & 80 Low Pressure Fabricated Fittings



45° Street Ell SCH 40

(Continued)

Spigot x Socket

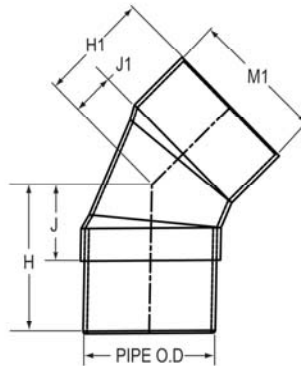

Part Number	Size	H	H1	J	J1	M1	Approx. Wt. (Lbs.)
3727-240	24	26-15/16	19-15/16	13-15/16	7-15/16	25-3/8	154.23

45° Street Ell SCH 80

Spigot x Socket

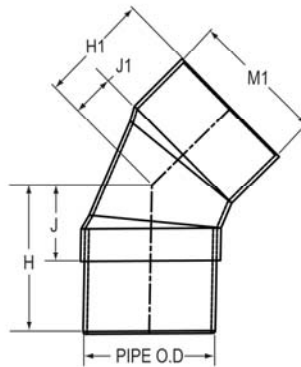

Part Number	Size	H	H1	J	J1	M1	Approx. Wt. (Lbs.)
3927-040	4	4-11/16	4-11/16	2-3/16	1-1/16	5-1/4	2.64
3927-060	6	5-3/8	5-3/8	2-1/8	2-1/8	7-1/2	7.01
3927-080	8	6-7/8	6-11/16	2-5/8	2-7/16	9-5/8	9.49
3927-100	10	8-7/16	8-9/16	3-3/16	3-5/16	11-15/16	19.54
3927-120	12	10-1/16	9-13/16	3-13/16	3-9/16	14-1/8	31.86
3927-140	14	11-9/16	11-9/16	4-9/16	4-9/16	15-1/2	41.24
3927-160	16	18-5/16	13-5/16	9-5/16	5-5/16	17-11/16	80.56
3927-180	18	20-1/2	15	10-1/2	6	19-7/8	117.40
3927-200	20	22-3/4	16-3/4	11-3/4	6-3/4	22-1/16	156.52
3927-240	24	27-3/16	20-3/16	14-3/16	8-3/16	26-7/16	271.75